

FLEETWOOD CHALLENGE CUP

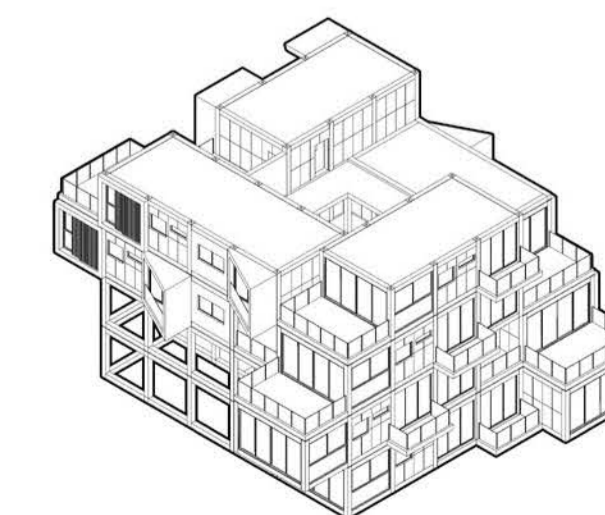

CONCEPT

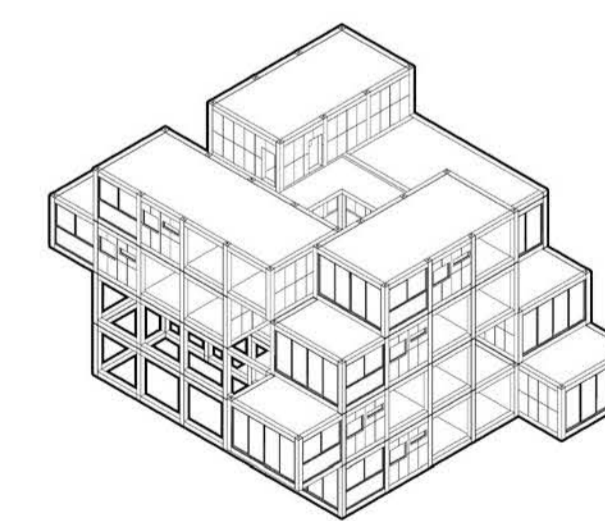
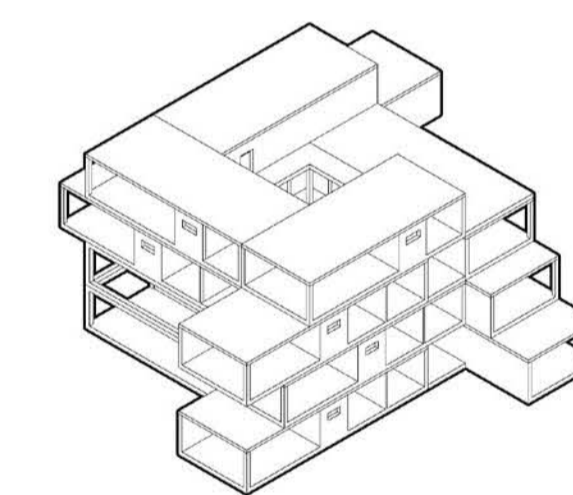
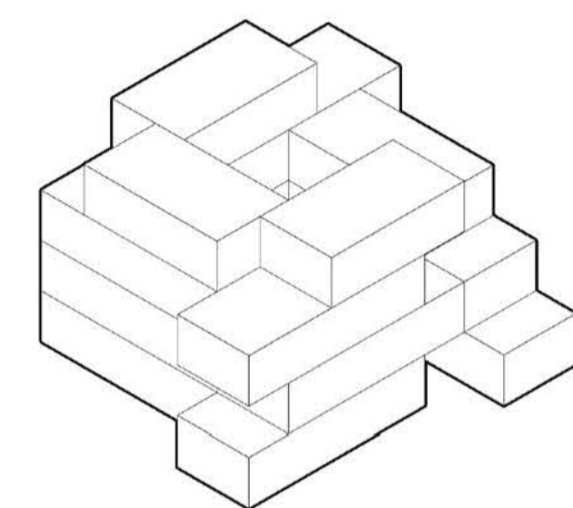
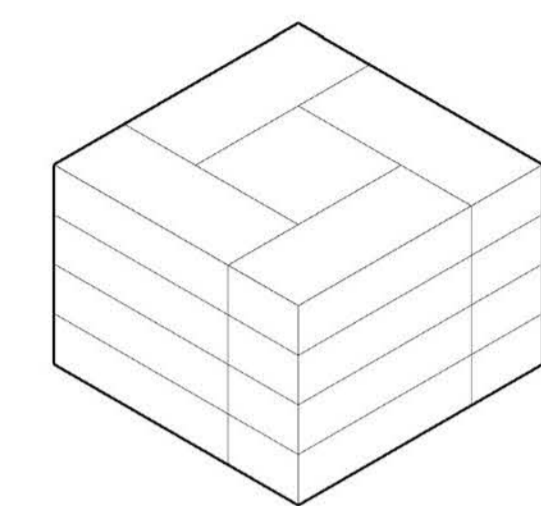
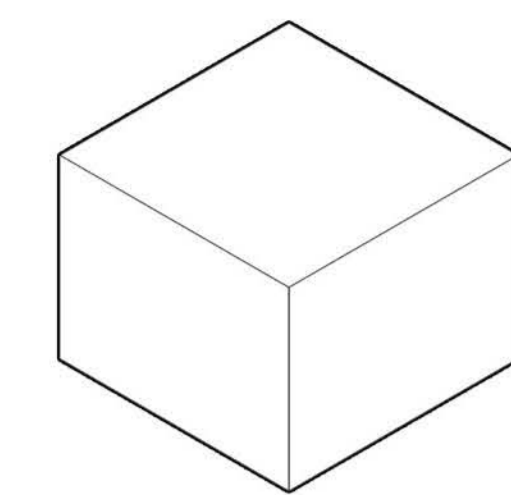
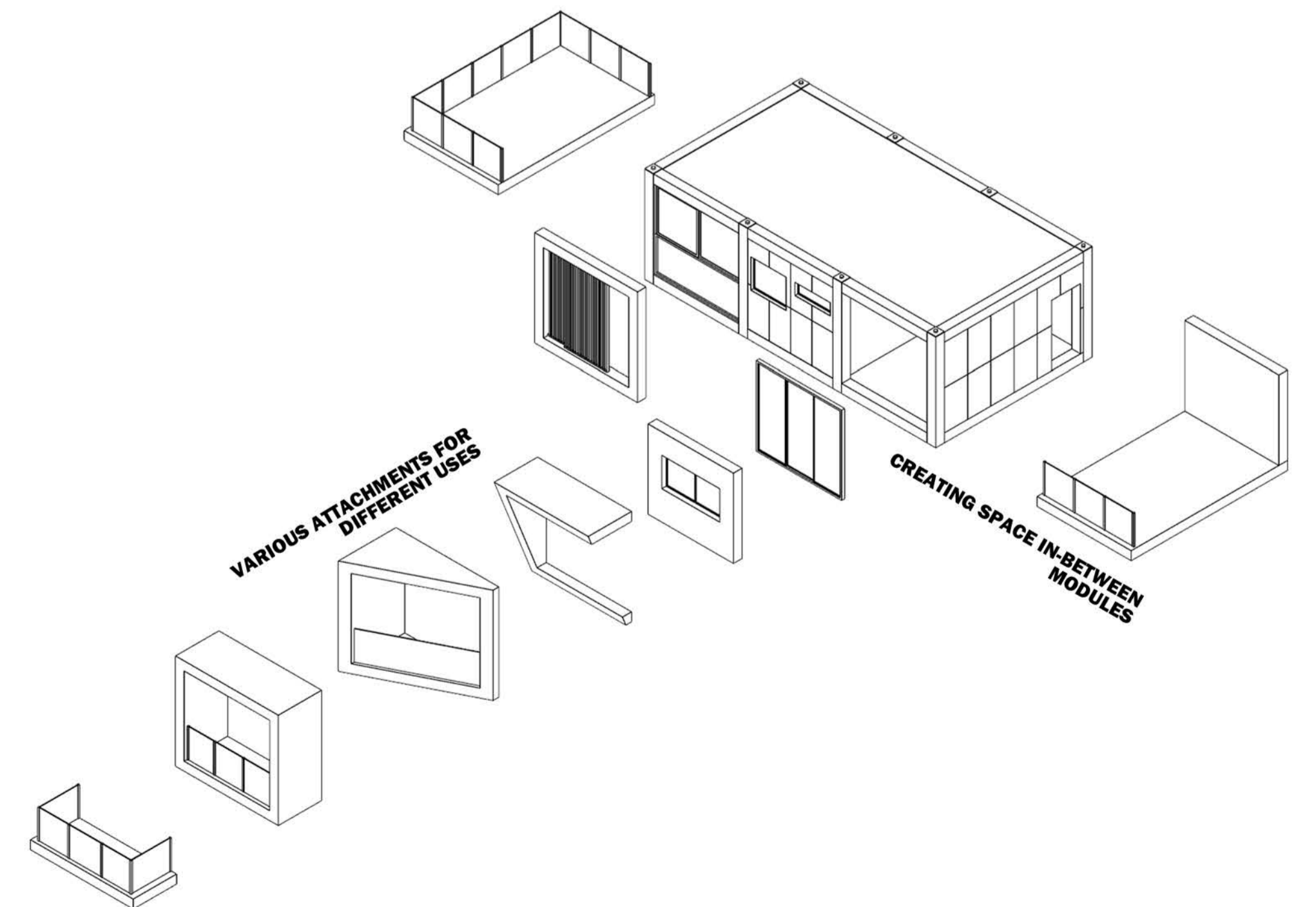
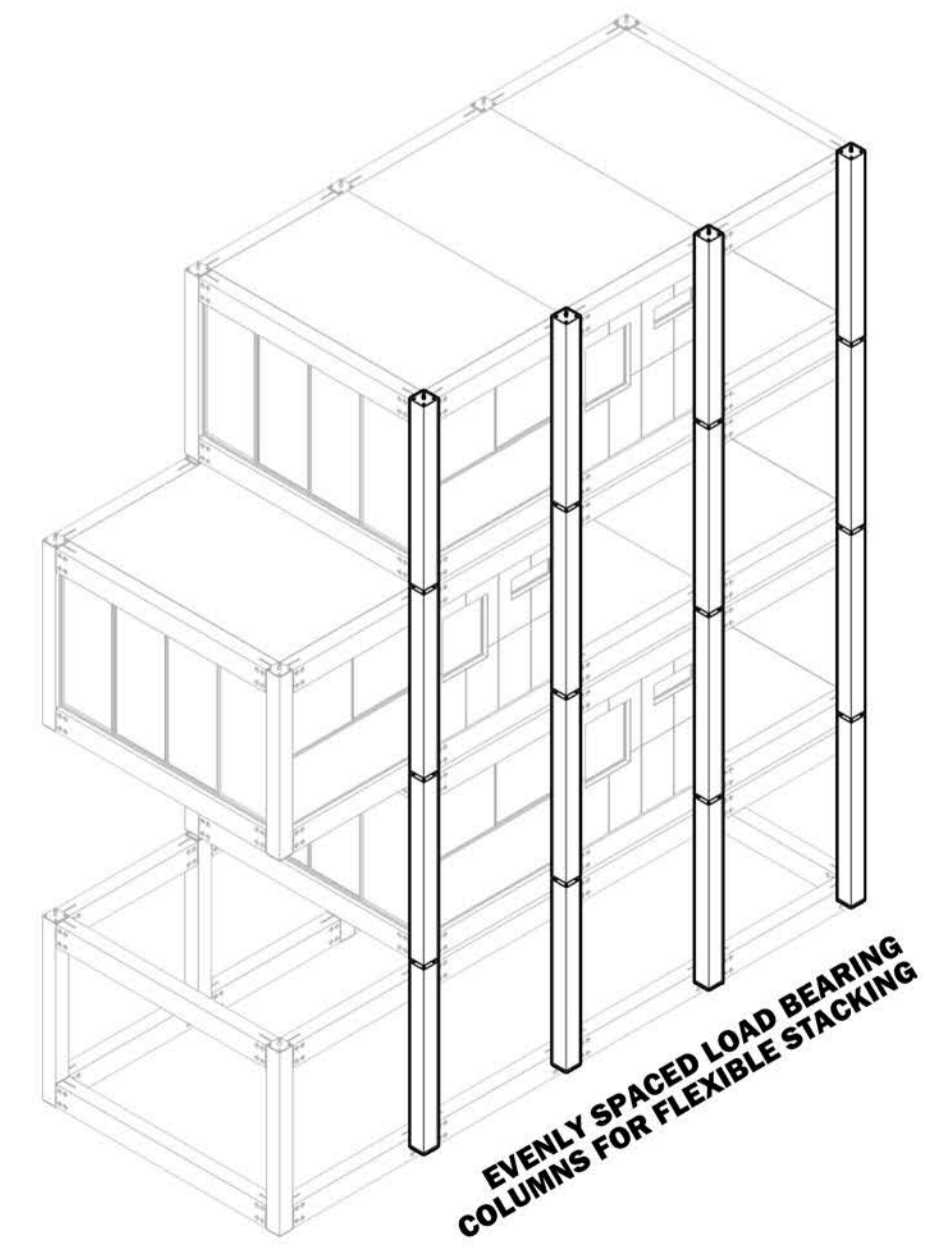
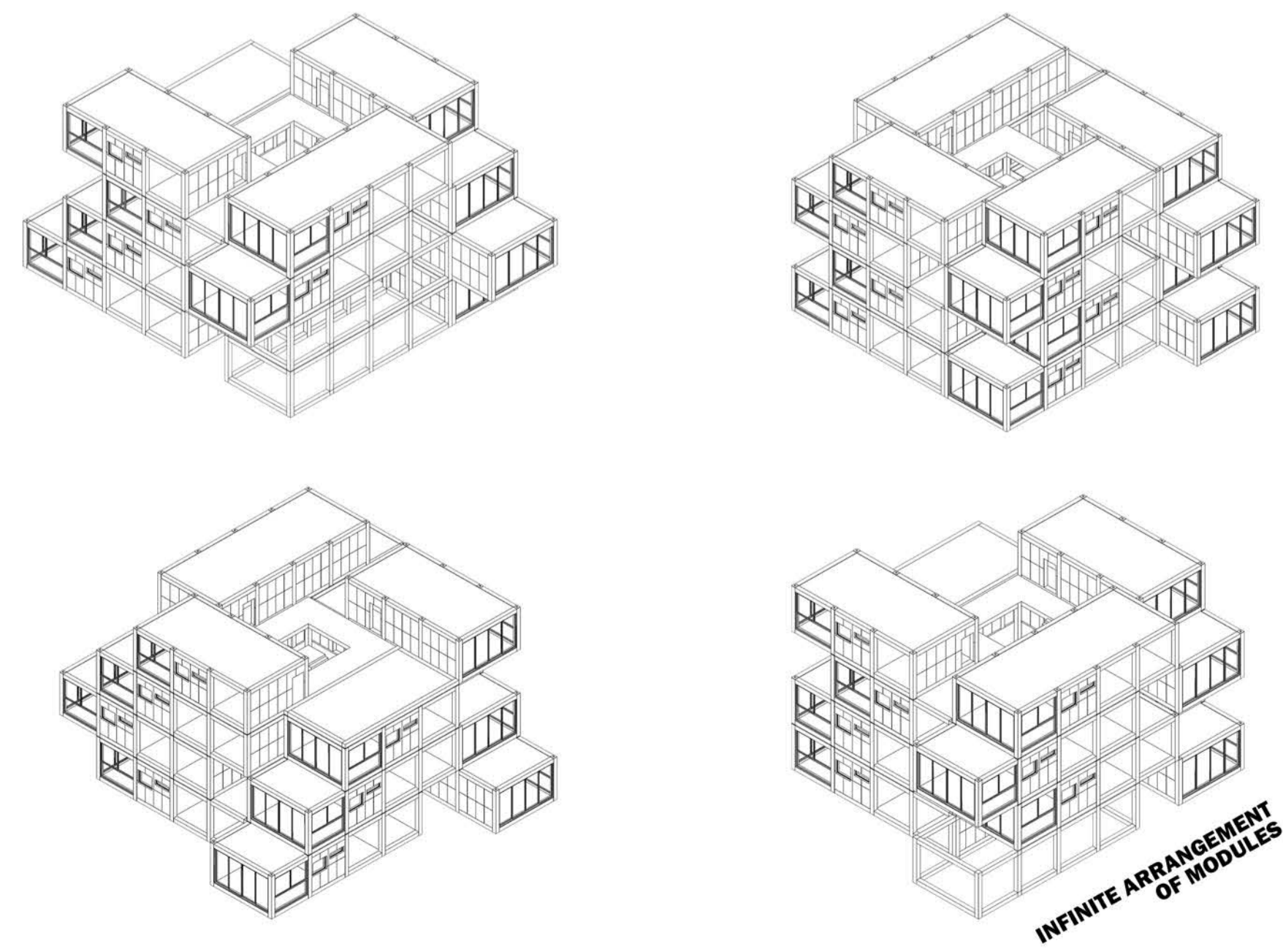
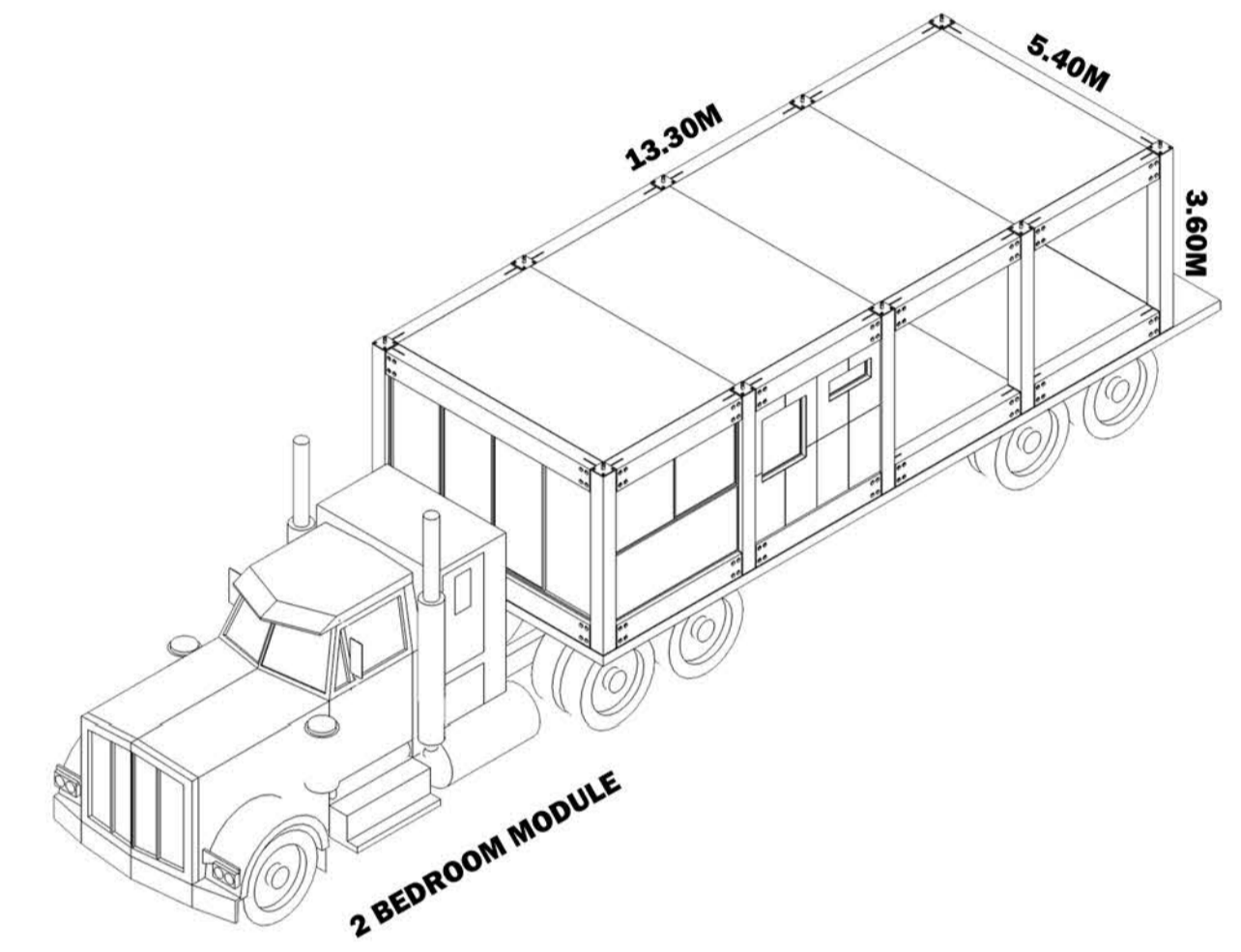
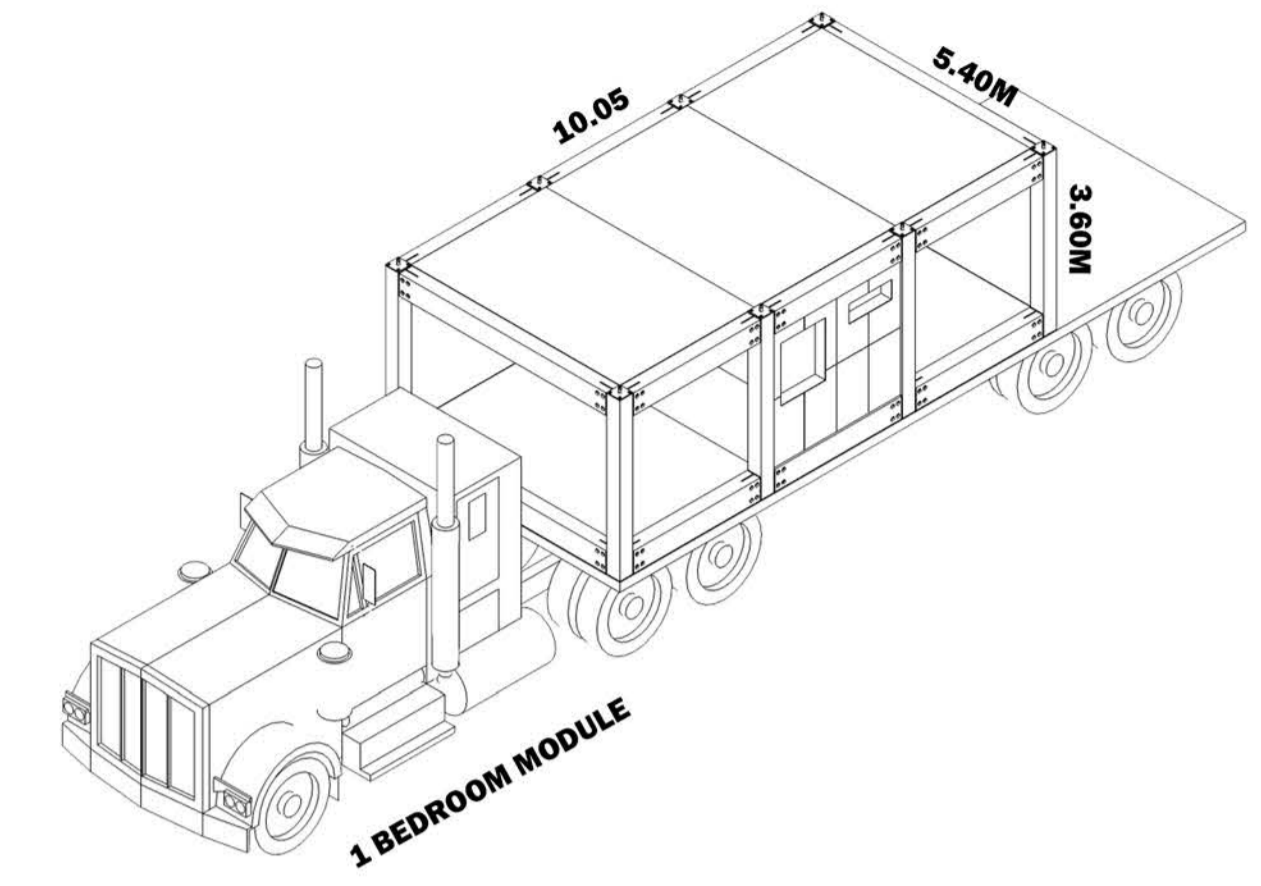
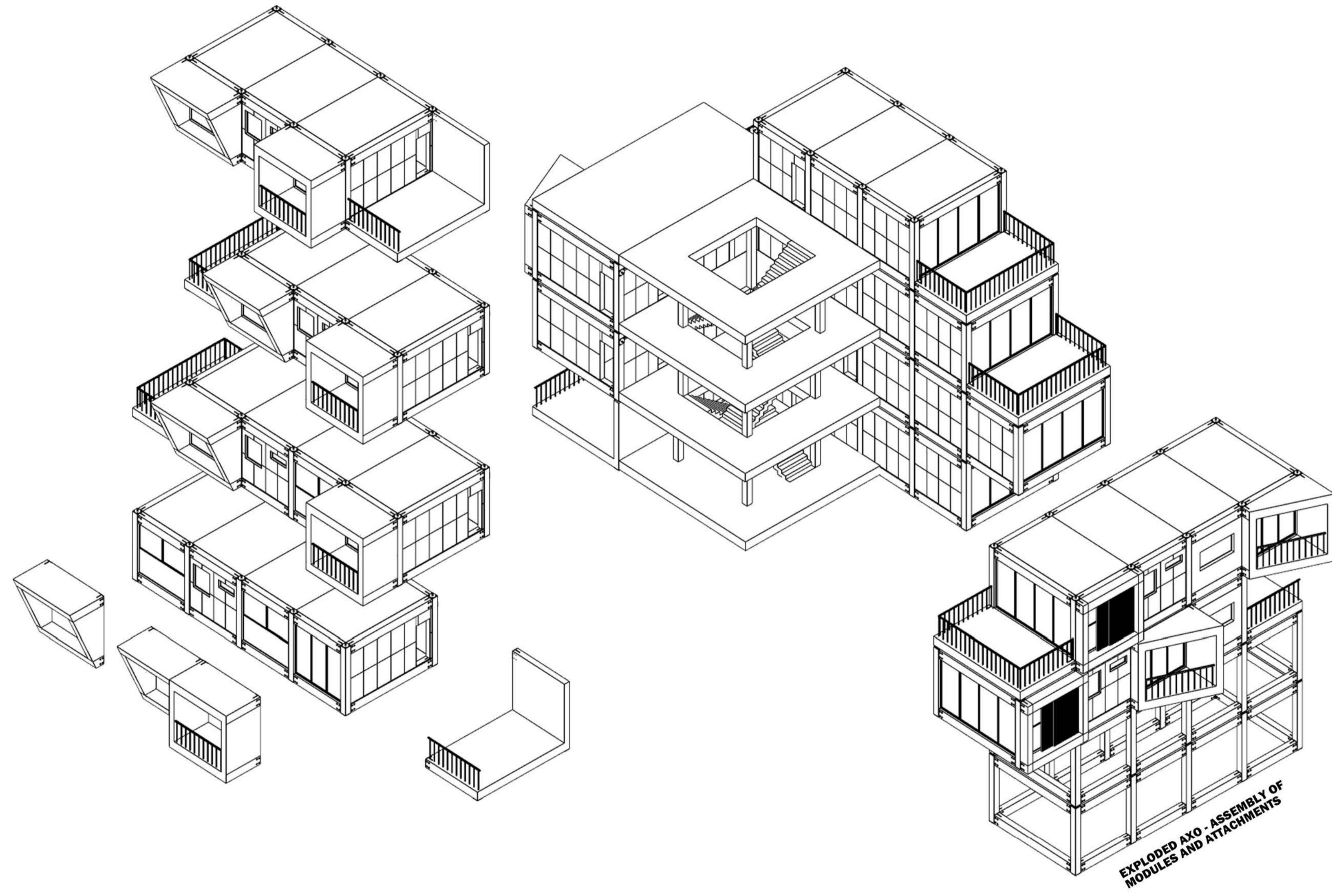

FLOOR PLANS

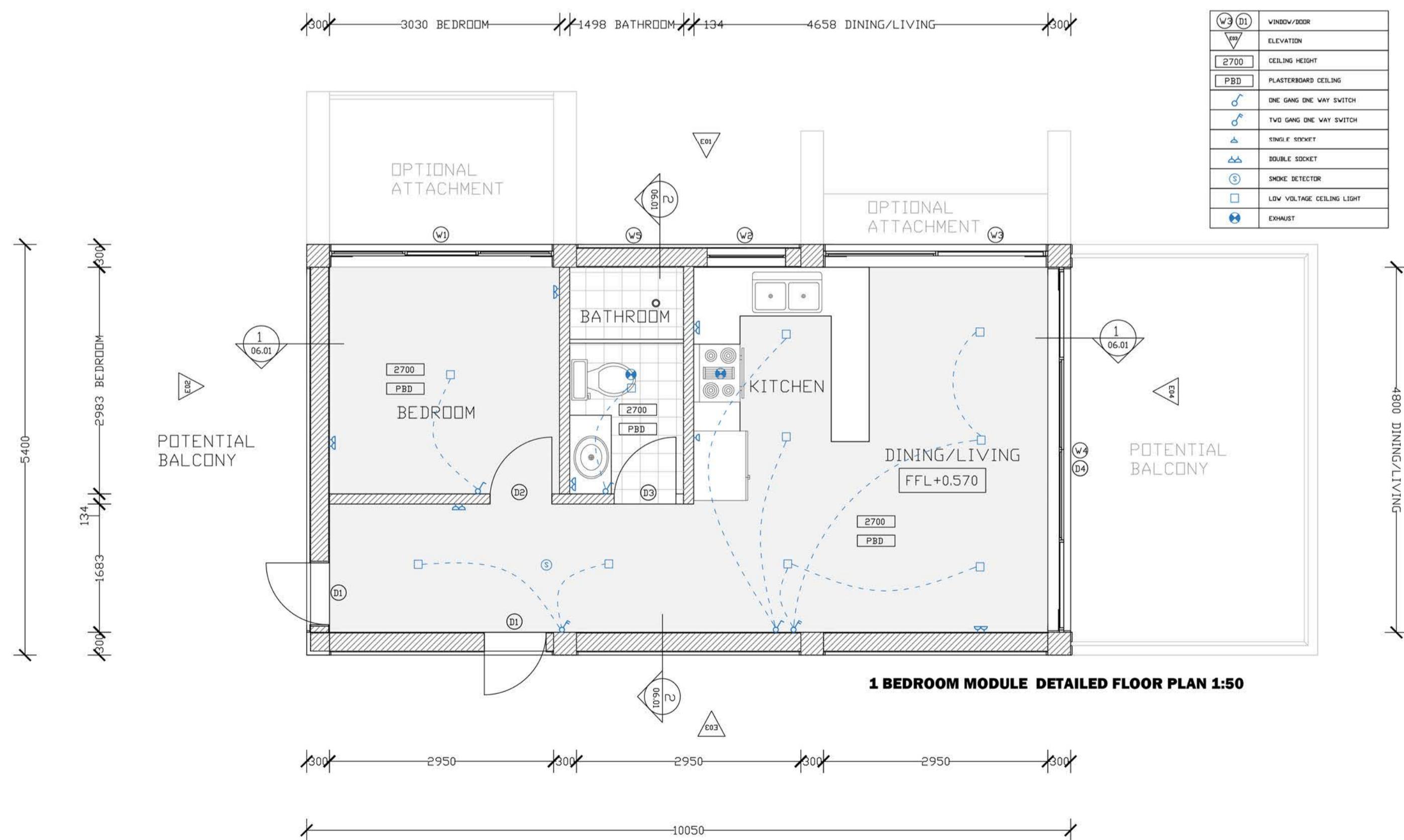
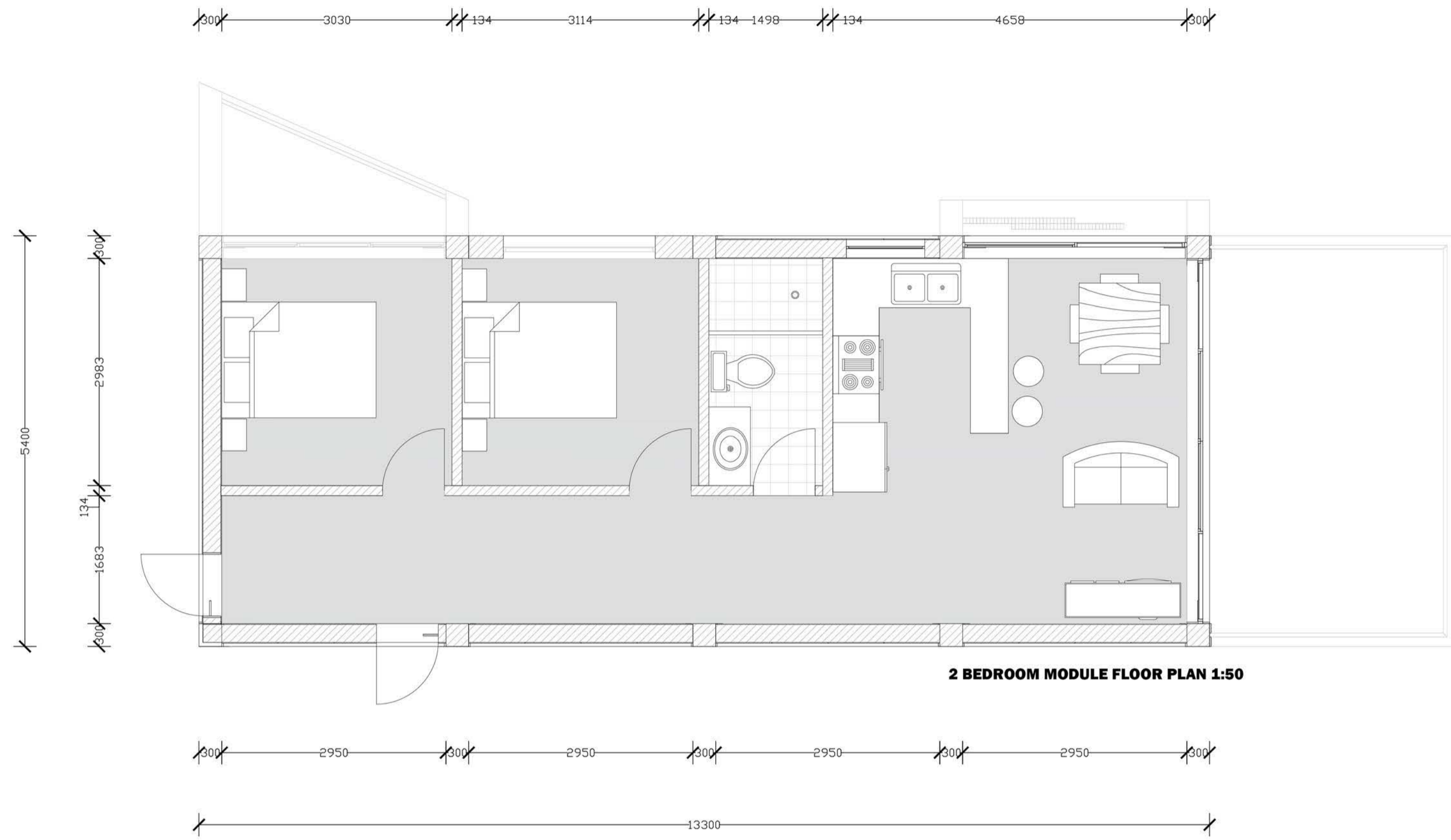

SITE PLAN

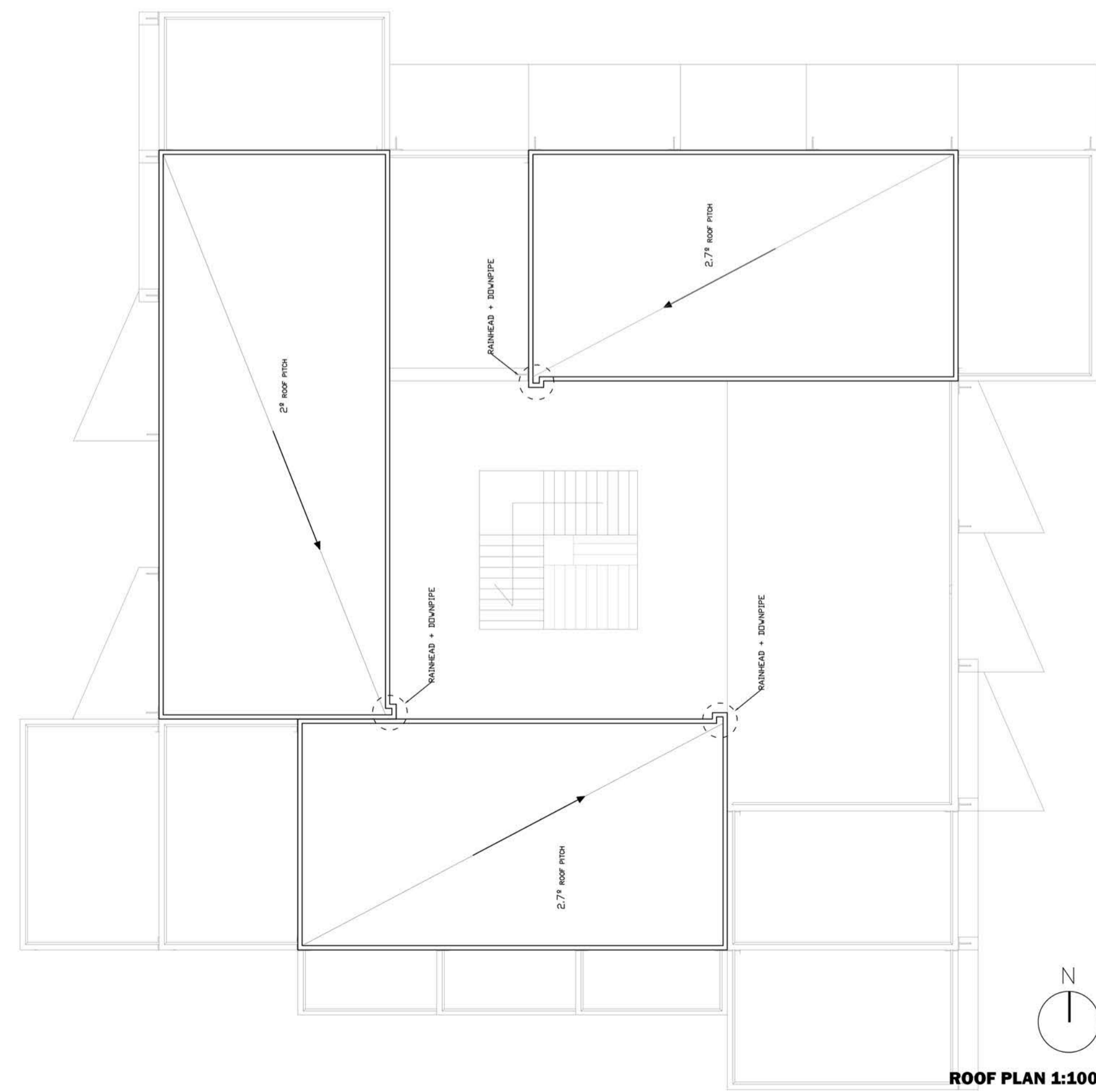
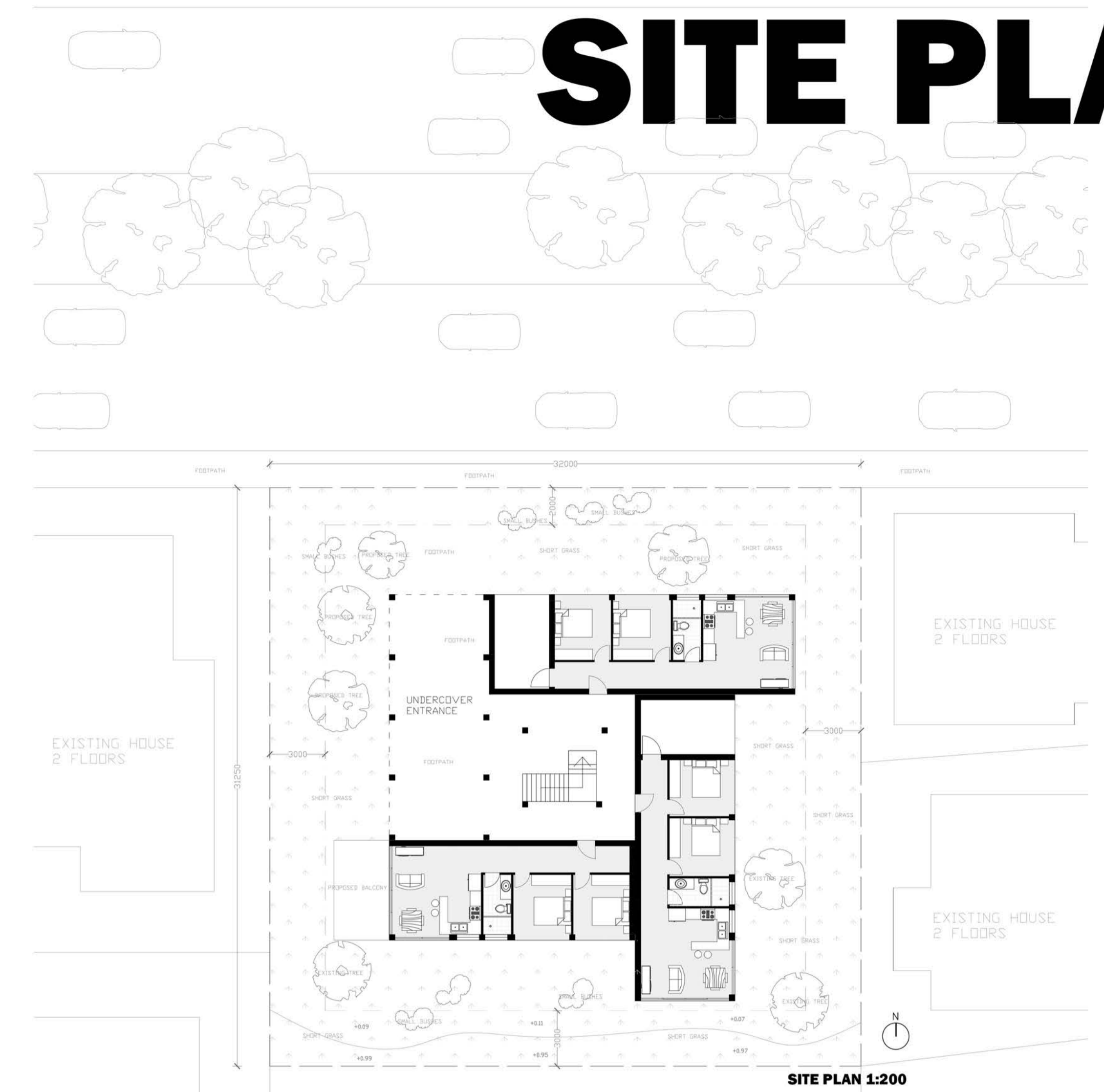
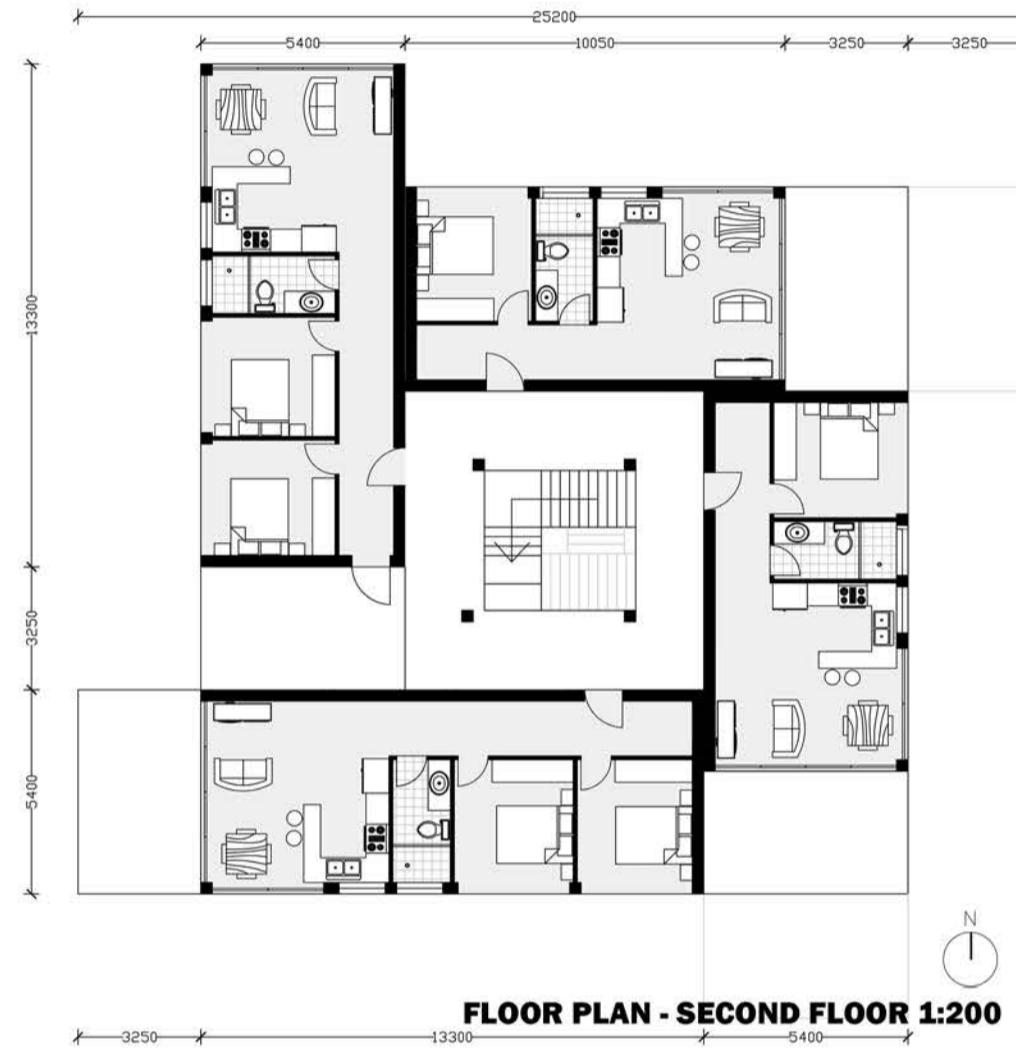
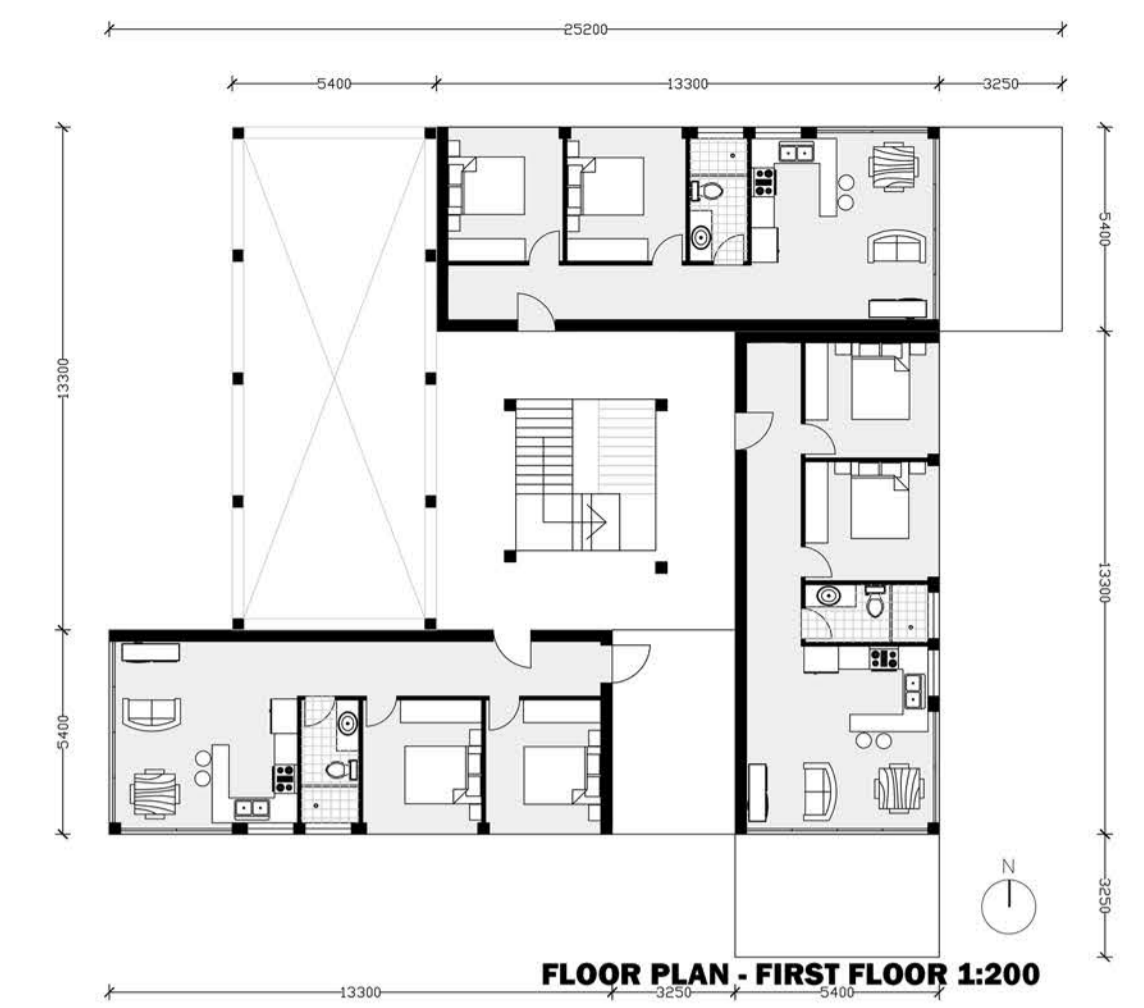

ELEVATIONS

1 BEDROOM MODULE ELEVATIONS

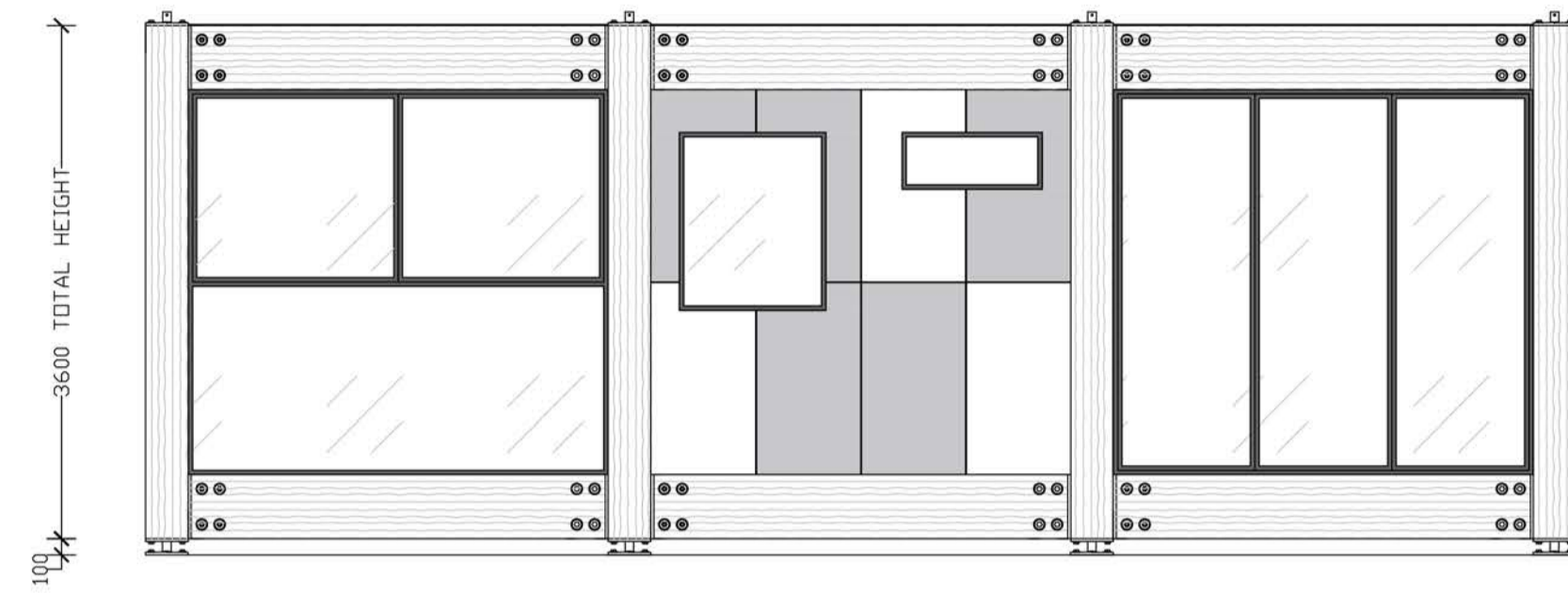

E01 ELEVATION 1:50

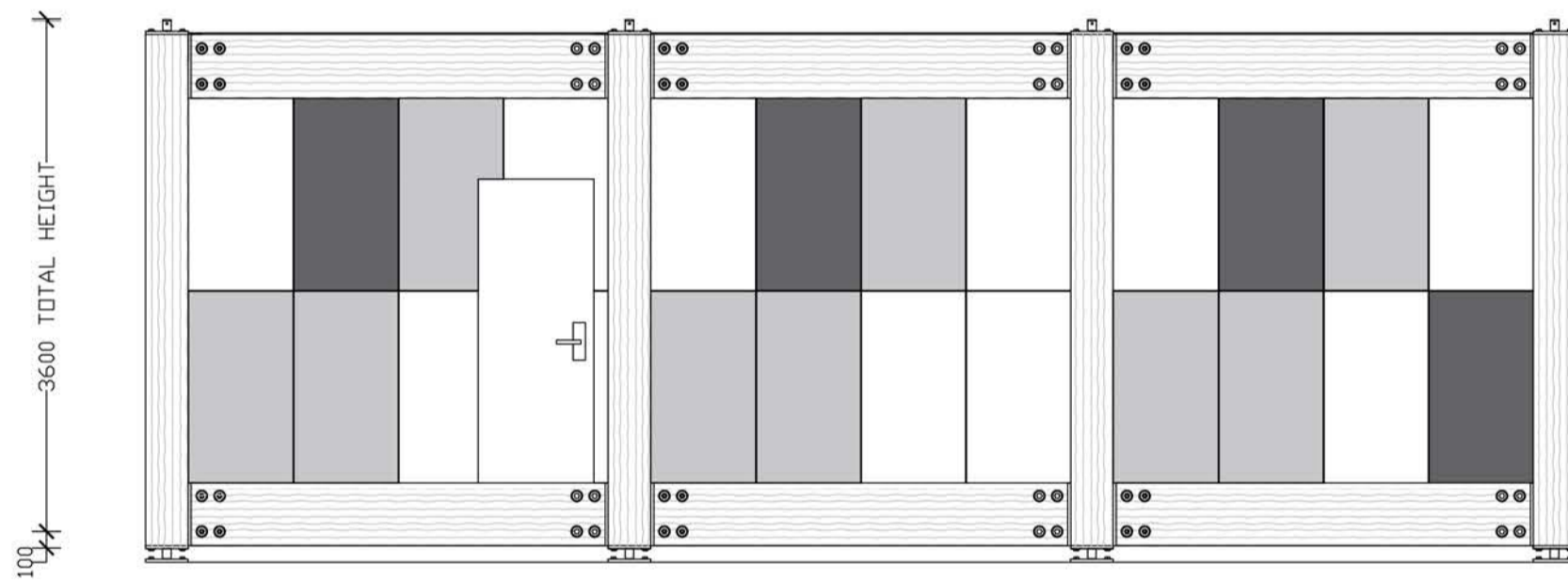

E03 ELEVATION 1:50

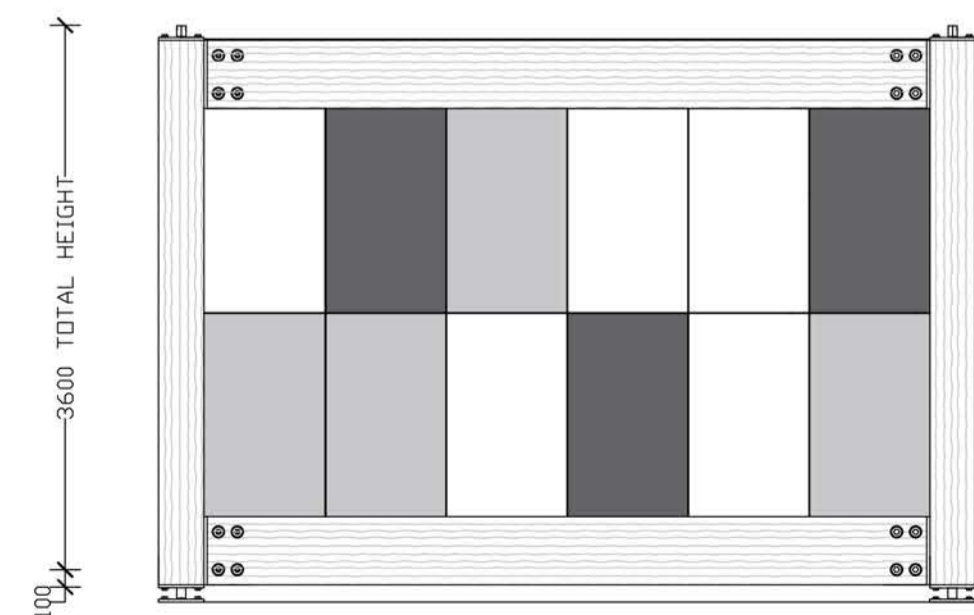

E02 ELEVATION 1:50

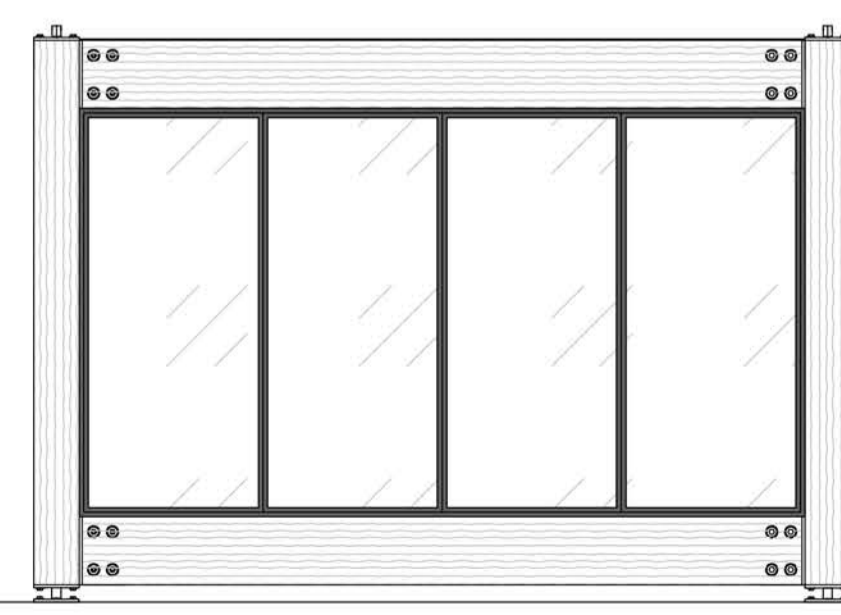

E03 ELEVATION 1:50



E06 WEST ELEVATION 1:50

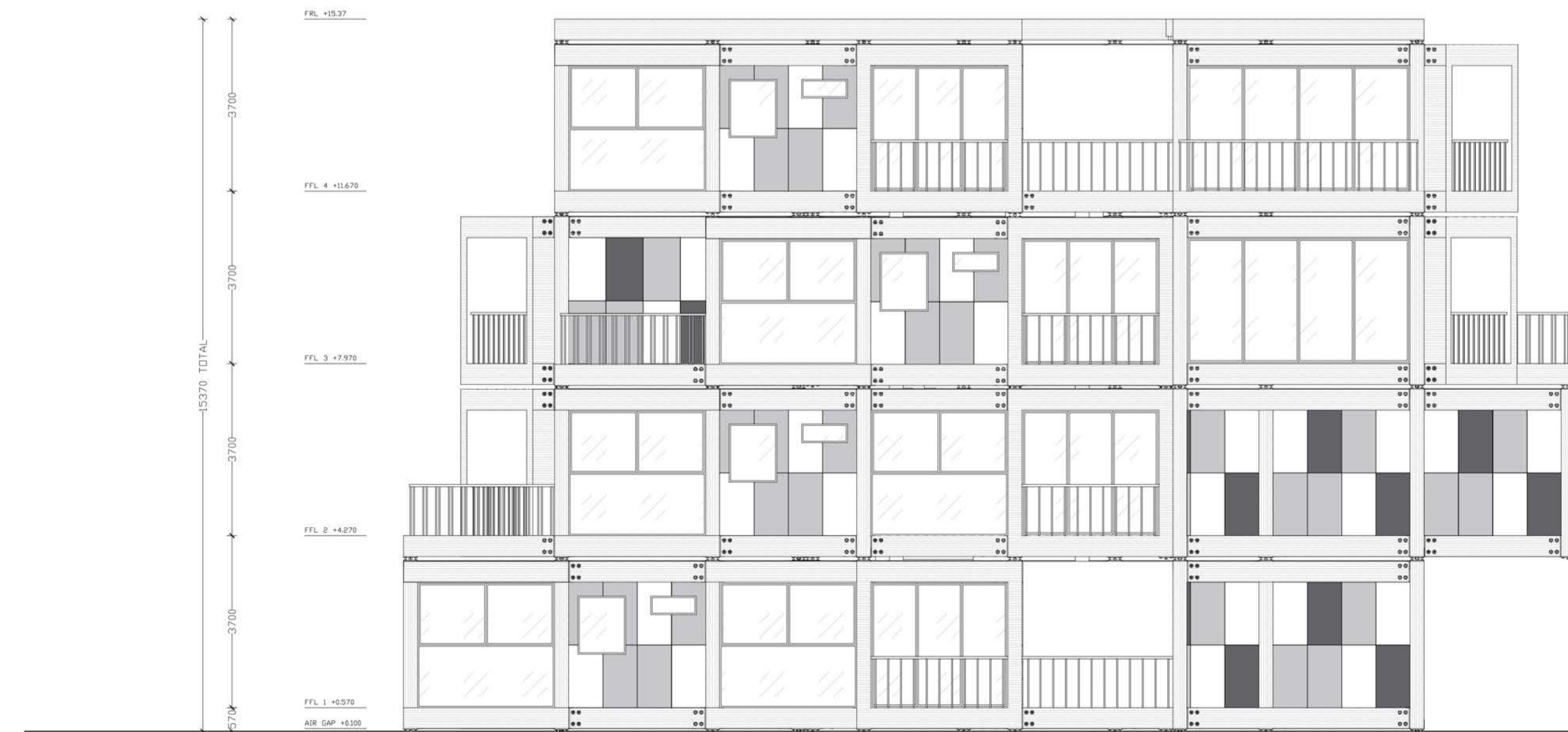

E05 NORTH ELEVATION 1:50

SECTIONS

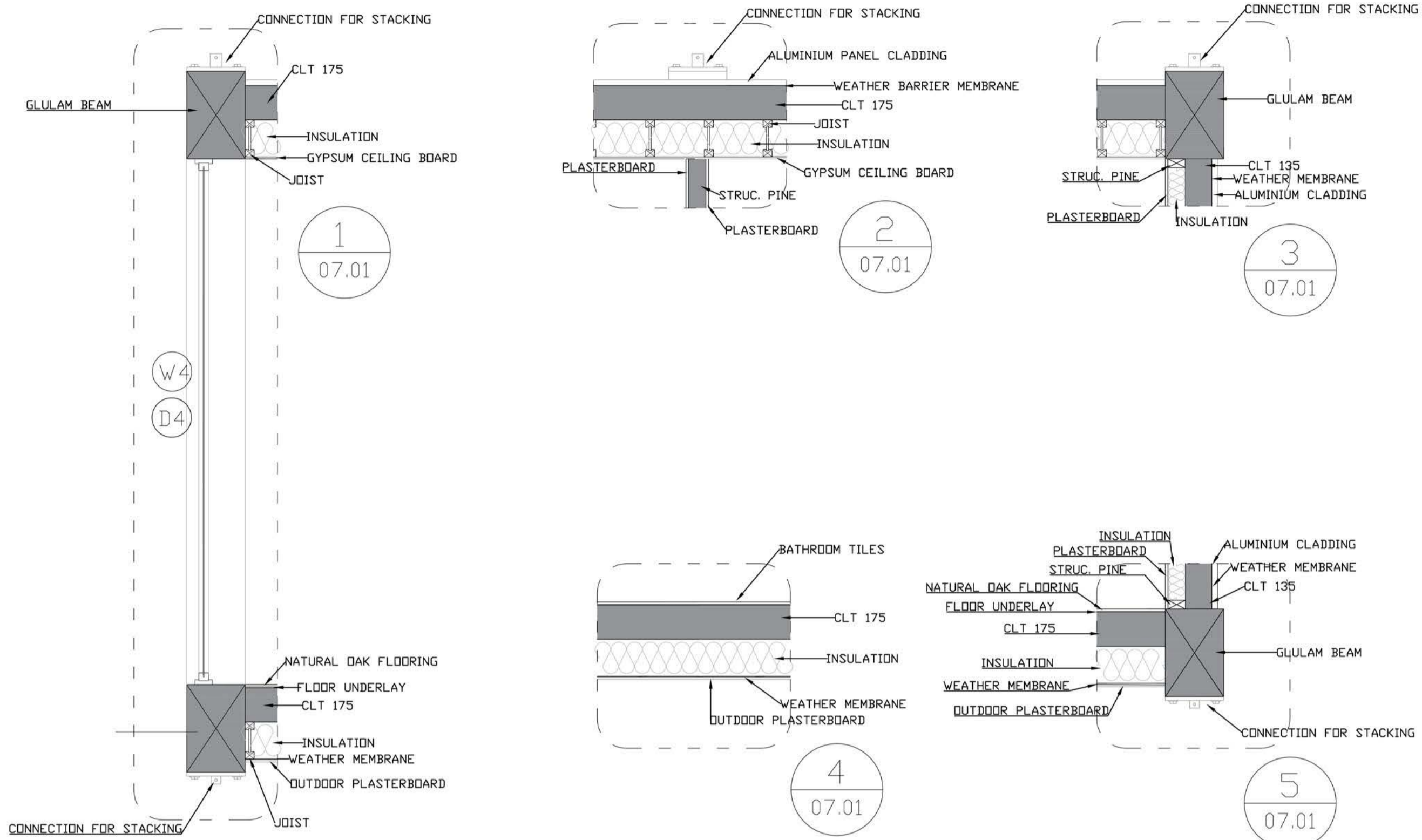

SECTIONAL DETAILS 1:20

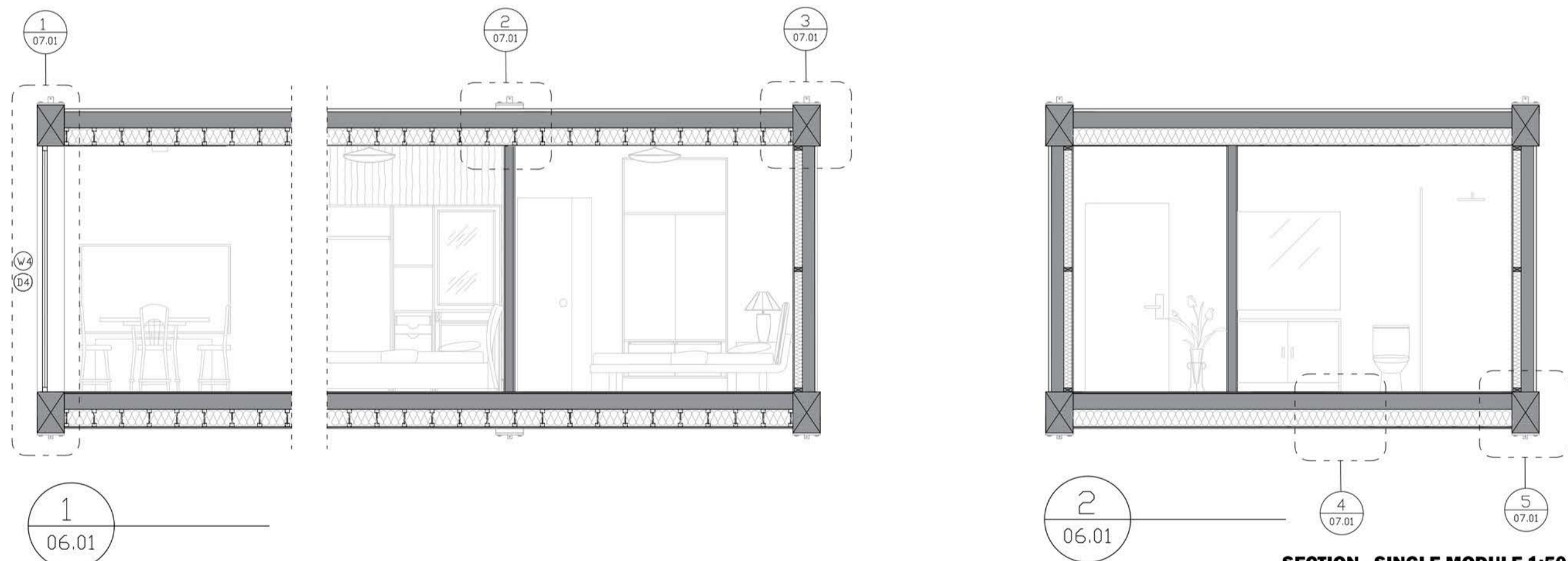

SECTION - SINGLE MODULE 1:50

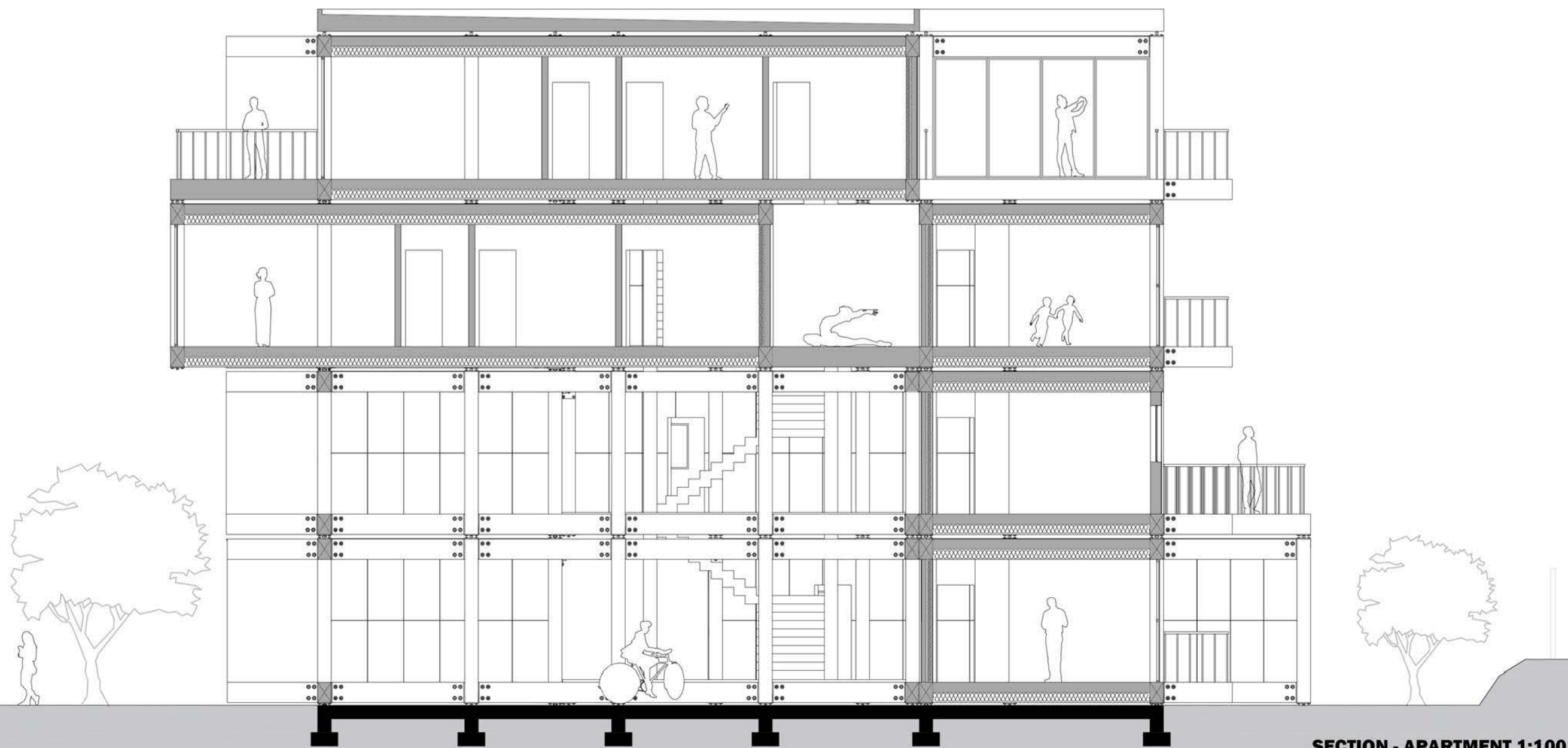

SECTION - APARTMENT 1:100





Executive Summary

Our engineering and architecture team has been given the challenge to design a four-storey modular building. Location of the site is in the suburbs of Melbourne, Australia. The building envelope is 1000m² with dimensions of 32m east-west and 31.25m north-south. Classified, a greenfield site, the site has a crossfall of 1m leading from the southern boundary to the northern boundary. Double storey dwellings exist either side of the building envelope with a 4-storey apartment to the rear of the southern boundary.

The modular design comprises a load bearing structural frame. Glulam beams and columns provide integral structural support to floors, walls, and ceiling. A slimline profile for walls, ceiling, and floor, is achieved through Cross laminated timber (CLT). A sustainable ethos governs the choice for an entirely wooden module design.

Gravity and lateral loads of the structure are channelled to the ground through one-way action of the floor and ceiling diaphragm to beams which transfer load by bending to columns. The bending and shear action imposed from the beams and wall shear is then transferred through connections between the beams and columns. A compression force and axial load onto the columns then transfers to the ground, where the column which is connected through concrete slab. The glulam columns are protected from water egress by a steel cuff. Unique attachments are connected by channel type connection to face of the building.

Construction of the module is completed off site then transported to site where assembly of the four-storey residential apartment complex is completed. The complex comprises of four standalone buildings forming a cube with north, south, east and west orientations. A central tower of stairs provides access to each floor. The eastern building additionally provides a two-storey height access to the building.

The objective for our team was to create a midrise building, valuing sustainability, construction speed, precision of elements and a lightweight robust structure. Today, buildings, coupled with their construction, are reported to be a 36% contributor to global energy use, accounting for 39% of CO₂ emissions. Alternative, sustainable construction materials are consequently rapidly evolving so that, the dependence on steel and concrete, can be reduced to counteract the impact on the environment. Population is projected to grow by 30% over the next 40 years.. With this magnifying reality, materials sourced for this design are intentionally chosen to reduce the building carbon footprint.

A preliminary design concept was then presented to the Engineering Team. Importance was placed on modernisation and flexibility for structure configuration. An iterative approach was employed while ideas evolved. The engineering team worked closely with the architect to bring the architects vision to reality, whilst, the engineers meshed structural integrity, practicality, and creativity.

Choice of Grades/Timber

- Initial timber choice was Structural Insulated Panels (SIPS), for all major structural elements such as walls, floors, and ceiling. Structural capacity of this lightweight engineered wood material seemed to tick all the boxes necessary for a robust light weight structure. However, further investigation to justify this material for midrise construction could not be validated. Recent changes in fire rating guidelines banned the use of SIPS for buildings greater than a 2-storey height. The use of polystyrene insulation embedded within the panels being the fundamental reason for the fire rating inadequacy of SIPS.
- Major structural elements chosen:

Framing Columns and Beams - Glulam

- Strength greater than steel largely contributed by the laminated process.
- Uniform and seasoned members accounts for less flaws and longer span ability.
- Caution needed to protect the base of columns from water ingress. This can be achieved through metal “cuff” protection at the base.

Walls, Floors and Ceiling - Cross laminated timber (CLT)

- A cassette floor system is used to span over the 5.4m width of the floor space.
- Services are conveniently concealed within the floor space.
- Deflection is limited with the use of the CLT’s unique arrangement of multi layered cross section providing high capacity with less weight.
- A highly sustainable material, as timber elements are kiln-dried and oriented 90-degree angles to each other, then glued with non-toxic adhesives.

Connections – Steel

Importance was placed on designing connections to:

- Limit transfer of vibration thru the building.
- Manage any settlement or movement of the structure.
- Manage creep of wooden elements imposed from moisture and loading.
- Provide a tolerance factor during on site assembly
- Advantageously allow constructability, ease and speed for onsite assembling.
- Mitigate the infiltration of water for possible damage.
- Allow for visible evaluation of connection performance over the life of the structure.

These material choices meet the vision of a sustainable objective.

- Lightweight structure achieved due to the density of wood being 650kg/m³ which represents approximately 400% reduction on density when compared with concrete and around 1200% lighter than steel.
- Economical gains – through mitigation of extensive ground preparation as would be required for a steel or concrete structure. Off-site construction considerably reduces the need for extensive work onsite, consequently large construction savings are realised.
- Fire resistance – unlike steel, timber develops a ‘char’ protective layer at around 250°C and, has ability to continue, providing structural load support, whilst the fire progresses. Steel, however, loses strength very quickly. Research shows that at 550°C, the bending capacity of steel will reduce by around 50% and at 750°C, bending capacity is further reduced by 90%. Timber behaviour is different, as the size of the member reduces through charring only then will the bending strength reduce. A fire rating of 90/90/90 is selected for all structure elements.

FLOOR	Material	Weight kg per m ³	Weight	Force kN per	Weight kg per m	Width (m)	Thickness (m)	Length (m)	Force kN/m
Floor Finish Cover 12mm	12mm Laimate Natural Oak		10.91	0.107			0.012	12.7	
Floor Underlay 5 mm	Hardie vinyl and cork underlay		8.4	0.082			0.005	12.7	
CLT5/175	XLAM	500	87.5	0.858			0.175		
Insulation/Air Gap	Gutex Thermofloor		3.4	0.033			0.1		
Fixing Block 200x45mm	Wesbeam e-beam	650		0	5.85		0.2	12.7	0.057
Joist 200x 45mm	Wesbeam e-joist	650		0	5.85	4.8	0.2	12.7	0.057
Weather Membrane	James Hardie	109	0.109	0.001			0.001		
Permarock Outdoor	Plasterboard Variant	1230	15.99	0.157			0.013		
Service Allowance	Additional 2.5% kN per m ²			0.031					
EXTERNAL WALL	Material	Weight kg per m ³	Weight	Force kN per	Weight kg per m	Width (m)	Thickness (m)	Length (m)	Force kN/m
Aluminium Cladding	MondoClad	2680	8.04	0.079			0.003		
Air Gap for Cladding	MonoClad			0			0.027		
Weather Membrane	James Hardie	109	0.109	0.001			0.001		
CLT3/105	XLAM	500	52.5	0.515			0.105		
Insulation & Air Gap	Gutex Thermosafe		8.8	0.086			0.08		
Struct. Pine(90x45mm)	Timber & Building Supplies	540		0	2.187	0.045	0.09		0.021
Plasterboard - 13mm	Sound Stop Plaster		7.2	0.071		4.8	0.013		
INTERNAL WALLS	Material	Weight kg per m ³	Weight	Force kN per	Weight kg per m	Width (m)	Thickness (m)	Length (m)	Force kN/m
PlasterBoard Front 13mm	Sound Stop Plaster		7.2	0.070632			0.013		
Insulation Airgap	Gutex - Thermosafe Homogean		8.8	0.086328			0.08		
Struct. Pine(90x45mm)	Timber & Building Supplies	540		0	2.187	0.045	0.09		0.021
Plasterboard Back 13mm	Sound Stop Plaster		7.2	0.070632			0.013		
CEILING	Material	Weight kg per m ³	Weight	Force kN per	Weight kg per m	Width (m)	Thickness (m)	Length (m)	Force kN/m
Aluminium	MondoClad	2710	8.13	0.08			0.003		
Weather Barrier Membrane	James Hardie	109	0.109	0.001			0.001		
CLT5/175	XLAM	500	87.5	0.858			0.175		
Insulation/Air Gap	Gutex - Thermoflat		8.8	0.086			0.08		
Fixing Block 200x45mm	Wesbeam e-beam	650		0	5.85	0.045	0.2	12.7	0.057
Joist 200x 45mm	Wesbeam e-joist	650		0	5.85	0.045	0.2	12.7	0.057
Gypsum ceiling board	Aussie plaster board		6.9	0.068			0.01		
COLUMNS & BEAMS	Material	Weight kg per m ³	Weight	Force kN per	Weight kg per m	Width (m)	Thickness (m)	Length (m)	Force kN/m
Beams	Glulam	650	87.75		0.3	0.45	2.95	3.235	0.8608
Columns	Glulam	650	58.5		0.3	0.3	3.6		0.5739

Calculations – Provided by engineers

1.1.1 Load Calculation for Single 2 Bedroom Module

The following loading calculations represent all loading combinations for the most critical module configuration, this being a 2 Bedroom Module on the North facing building. Analysis of the loading found the critical combination to be 1.2G + 1.5Q when considering bending, shear and axial reactions. The deflection was found to be critical on Eastern Building where wind and uplift were the governing factors and a loading combination of 1.2G + Wu + ψcQ with maximum deflection shown as -11.2mm, this was considered in Spacegass with a reduced modulus of 80% to account for creep as a worst case scenario.

Ultimate limit state strength loading for top beams, bottom beams and columns of critical 2 bedroom module are as shown in the Table 1, Table 2 and Table 3 respectively.

Table 1: Structural Load calculated for Top beams

TOP BEAMS LOADING						ULTIMATE STATE STRENGTH (kN/m)			
	Permanent Module (kN/m) (not inc selfweight)	Perm. Load Attach.(kN/m)	TOTAL PERMANENT LOADS (G) kN/m	IMPOSED (kN/m)	WIND (kN/m)	1.2G + 1.5Q	1.2G + 1.5 ψ l*Q	1.2G+Wu+ ψcQ	0.9G+Wu
North Beam 1	6.203		6.203	0.600	0.277	8.344	7.804	7.961	5.860
North Beam 2	6.203		6.203	0.600	0.277	8.344	7.804	7.961	5.860
North Beam 3	6.203		6.203	0.600	0.277	8.344	7.804	7.961	5.860
North Beam 4	6.203		6.203	0.600	0.277	8.344	7.804	7.961	5.860
South Beam 1	6.203		6.203	0.600	0.277	8.344	7.804	7.961	5.860
South Beam 2	6.203		6.203	0.600	0.277	8.344	7.804	7.961	5.860
South Beam 3	6.203	1.655	7.859	0.600	0.277	10.331	9.791	9.947	7.350
South Beam 4	6.203	1.655	7.859	0.600	0.277	10.331	9.791	9.947	7.350
East Beam	0.685		0.685	0.600	0.277	1.721	1.181	1.338	0.893
West Beam	0.685		0.685	0.600	0.277	1.721	1.181	1.338	0.893

Table 2: Structural Load calculation for bottom beams

BOTTOM BEAMS LOADING						ULTIMATE STATE STRENGTH (kN/m)			
	Permanent Module (inc SW Beam) (kN/m)	Perm. Load Attach.(kN/m)	TOTAL PERMANENT LOADS (G) kN/m	IMPOSED (kN/m)	WIND LOAD (kN/m)	1.2G + 1.5Q	1.2G + 1.5 ψ l*Q	1.2G+Wu+ ψcQ	0.9G+Wu
North Beam 1	10.247		10.247	0.600	0.277	13.196	12.656	12.813	9.499
North Beam 2	10.247		10.247	0.600	0.277	13.196	12.656	12.813	9.499
North Beam 3	10.247		10.247	0.600	0.277	13.196	12.656	12.813	9.499
North Beam 4	10.247		10.247	0.600	0.277	13.196	12.656	12.813	9.499
South Beam 1	11.748		11.748	0.600	0.277	14.997	14.457	14.614	10.850
South Beam 2	10.247		10.247	0.600	0.277	13.196	12.656	12.813	9.499
South Beam 3	11.748	1.655	13.403	0.600	0.277	16.984	16.444	16.601	12.340
South Beam 4	11.748	1.655	13.403	0.600	0.277	16.984	16.444	16.601	12.340
East Beam	2.907		2.907	0.600	0.277	4.388	3.848	4.005	2.893
West Beam with SD	2.186	1.655	3.841	0.600	0.277	5.509	4.969	5.126	3.734

Table 3 Structural Load calculation for Column

COLUMN LOADING							ULTIMATE STATE STRENGTH (kN/m)			
	Self Weight Only Permanent Module (kN)	Beams Permanent Loading (kN)	Permanent Attach. Loading (kN)	TOTAL PERMANENT LOADS (G) kN	IMPOSED (kN)	WIND LOAD (kN)	1.2G + 1.5Q	1.2G + 1.5 ψ l*Q	1.2G+Wu+ ψcQ	0.9G+Wu
North Column 1	1.49	31.15		32.64	0.13	0.66	39.36	39.24	39.88	30.04
North Column 2	1.49	48.53		50.01	0.13	0.66	60.21	60.09	60.73	45.68
North Column 3	1.49	48.53		50.01	0.13	0.66	60.21	60.09	60.73	45.68
North Column 4	1.49	48.53		50.01	0.13	0.66	60.21	60.09	60.73	45.68
North Column 5	1.49	32.88		34.37	0.13	0.66	41.44	41.32	41.96	31.60
South Column 1	1.49	35.10		36.58	0.13	0.66	44.09	43.98	44.62	33.59
South Column 2	1.49	48.53		50.01	0.13	0.66	60.21	60.09	60.73	45.68
South Column 3	1.49	52.96	5.96	60.40	0.13	0.66	72.68	72.56	73.20	55.03
South Column 4	1.49	52.96	5.96	60.40	0.13	0.66	72.68	72.56	73.20	55.03
South Column 5	1.49	35.10		36.58	0.13	0.66	44.09	43.98	44.62	33.59

1.1.2 Spacegass Analysis Representation

Bending Moment – Critical

North oriented building has been considered critical as per the arrangement. Therefore, critical bending of -19.5 kNm of 1.2G + 1.5Q load combination has been considered for design of the beam. Spacegass reaction for bending moment is as shown in Figure 1.

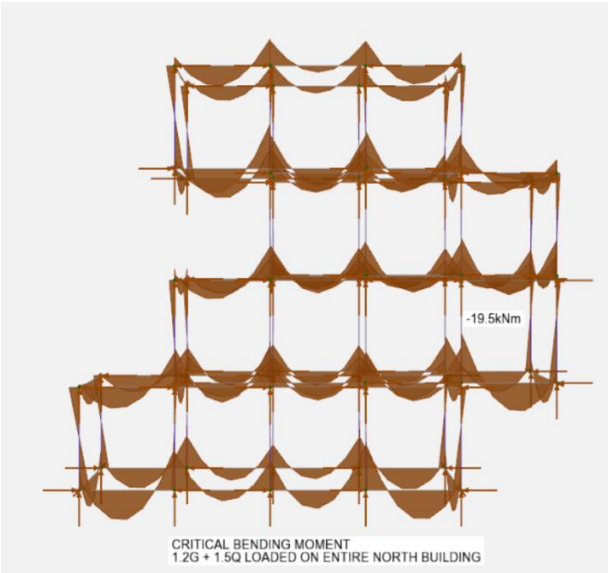

Figure 1: Critical Bending Moment from Spacegass

Shear Force – Critical

North oriented building has been considered critical as per the arrangement. Therefore, critical shear force of 63kN of 1.2G + 1.5Q load combination has been considered for design of the beam. Spacegass reaction for shear force is as shown in Figure 2.

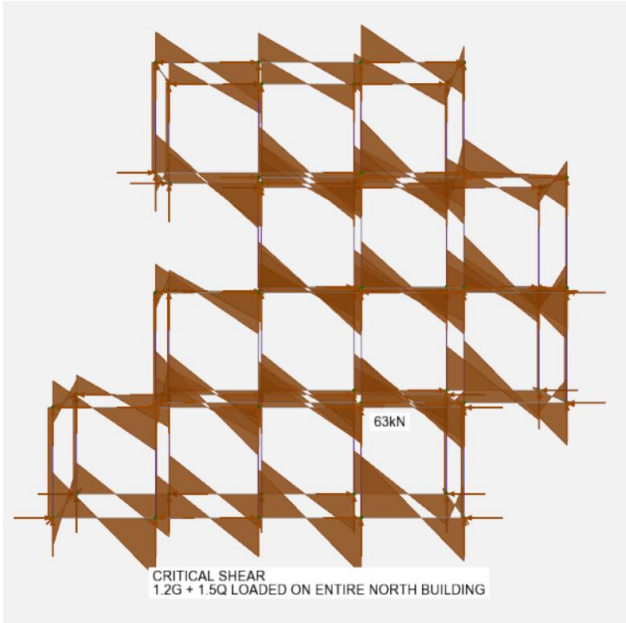

Figure 2: Critical Shear Force from Spacegass

Axial Force – Critical

North oriented building has been considered critical as per the arrangement. Therefore, critical axial force of 221 kN of 1.2G + 1.5Q load combination has been considered for design of the beam. Spacegass reaction for the axial force is as shown in Figure 3.

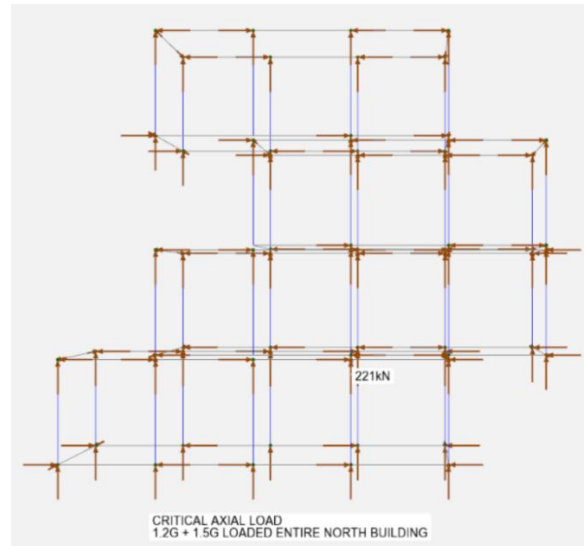

Figure 3: Critical Axial Force from Spacegass

Deflection – Critical

North oriented building has been considered critical as per the arrangement. Therefore, critical deflection of 2.2 mm of 1.2G + Wu + ψ cQ load combination has been considered for design of the beam. Spacegass reaction for deflection is as shown below.

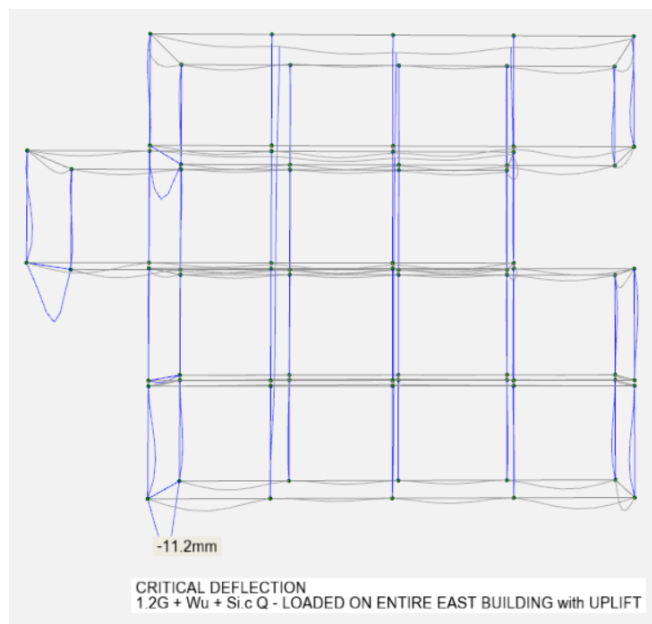

Figure 4: Critical Deflection from Spacegass

1.2 Beam Design Calculations – North and South Beams 1-4

Beam Dimension	Governing Load Case
Stress Grade = GL 17	1.2G + 1.5Q = 16.98 kN/m
B = 249 mm	M* = -19.5 kNm
D = 395 mm	V* = 63kN
L = 2.95 m	

1.2.1 Bending Strength

Design Bending Capacity, < AS1720.1.2010, 3.2.1.1 >

$$M_d \geq M^*$$

Clause AS1720.1.2010, E3.2(2)

$$M_d = \phi k_1 k_4 k_6 k_{12} f'_b Z$$

Glue-laminated timber-AS/NZS 1328.1

- Capacity Factor ϕ , <AS1720.1.2010, T 2.1 >

Category 2 – Elements in house for which failure would be likely to affect an area greater than 25 m².

$$\phi = 0.85$$

- Modification Factor k_1 , <AS1720.1.2010, T 2.3 >

For 50+ years duration of the load factor for strength

$$k_1 = 0.57$$

- Factor for in service absorption or desorption of moisture by timber 2.4.2

Seasoning Factor k_4 , <AS1720.1.2010, CL 2.4.2.3 >

Assumed moisture content of 15%

$$k_4 = 1$$

- Factor for temperature/humidity effect 2.4.3

Factor k_6 , <AS1720.1.2010, CL 2.4.3 >

Assumed no modifications need be made with regards to temperature

$$k_6 = 1$$

- Factor for sharing strength for glued laminated timber 7.4.3

Factor k_9 , <AS1720.1.2010, CL 7.4.3>

$$k_9 = 1$$

- Factor for stability for glued laminated timber 7.4.4

Ratio temporary design action effect/ total design action effect (r) = 0.053

Material Constant ρ_b for GL 17, <AS1720.1.2010, T 7.2(A)>

$$\rho_b = 0.88$$

TABLE 7.2(A)
MATERIAL CONSTANT, ρ_b , FOR BEAMS

Stress grade	Ratio temporary design action effect/total design action effect (r) [*]				
	0	0.25	0.5	0.75	1.0
	Material constant (ρ_b) for beams [†]				
GL18	0.89	0.89	0.85	0.83	0.82
GL17	0.88	0.88	0.85	0.83	0.81
GL13	0.90	0.90	0.86	0.84	0.83
GL12	0.84	0.84	0.81	0.79	0.78
GL10	0.85	0.85	0.81	0.79	0.78
GL8	0.88	0.88	0.84	0.82	0.81

* See Paragraph E2.

† These values are derived from Equation E2(1), Appendix E using values of E and f'_b given in Table 7.1.

- Slenderness coefficient for lateral buckling under bending, <AS1720.1.2010, CL 3.2.3.2>
Beam is loaded along its compression edge and has a continuous lateral resistant system along the compression edge.

$$S_1 = 0$$

- Stability Factor, <AS1720.1.2010, CL 3.2.4>

$$\rho_b S_1 = 0 \leq 10$$

$$k_{12} = 1$$

- Characteristic Bending f'_b Value for structural design, <AS1720.1.2010, T 7.1>

$$f'_b = 40 \times 10^3 \text{ kPa}$$

TABLE 7.1
CHARACTERISTIC VALUES FOR STRUCTURAL DESIGN—GL-GRADES

Stress grade	Characteristic values, MPa					
	Bending (f'_t)	Tension parallel to grain (f'_t)	Shear in beam (f'_v)	Compression parallel to grain (f'_c)	Short duration average modulus of elasticity parallel to the grain (E)	Short duration average modulus of rigidity for beams (G)
GL18	45	25	5.0	45	18500	1230
GL17	40	20	4.2	33	16700	1110
GL13	33	16	4.2	26	13300	900
GL12	25	11	4.2	22	11500	770
GL10	22	8	3.7	18	10000	670
GL8	19	6	3.7	14	8000	530

NOTE: The characteristic values for tension for GL grades apply for tension members with the larger cross-sectional dimension not greater than 150 mm. For tension members with a cross-sectional dimension greater than 150 mm, the characteristic values are determined by multiplying the value in the table by $(150/d)^{0.65}$, where d is the larger cross-sectional dimension of the section.

- Section modulus of beam $Z = bd^2/6$, <AS1720.1.2010, CL 3.2.1.1>

$$Z = \frac{0.249 \times 0.395^2}{6} = 0.0065 \text{ m}^3$$

Clause AS1720.1.2010, E3.2(2)

$$M_d = \phi k_1 k_4 k_6 k_9 k_{12} f'_b Z$$

$$M_d = 0.85 * 0.57 * 1 * 1 * 1 * 40 \times 10^3 * 0.0065$$

$$M_d = 125.5 \text{ kNm}$$

$$M_d = 125.5 \text{ kNm} \geq M^* = -19.5 \text{ kNm}$$

Bending moment demand = -19.5 kNm, less than the allowable limit which is 125.5 kNm.

1.2.2 Shear Strength

Flexural Shear Strength, <AS1720.1.2010, 3.2.5>

$$V_d \geq V^*$$

Clause AS1720.1.2010, E3.2(14)

$$V_d = \phi k_1 k_4 k_6 f'_s A_s$$

- Capacity Factor ϕ , <AS1720.1.2010, T 2.1>

Category 2 – Elements in house for which failure would be likely to affect an area greater than 25 m².

$$\phi = 0.85$$

- Modification Factor k_1 , <AS1720.1.2010, T 2.3>

For 50+ years duration of the load factor for strength

$$k_1 = 0.57$$

- Factor for in service absorption or desorption of moisture by timber 2.4.2

Seasoning Factor k_4 , <AS1720.1.2010, CL 2.4.2.3>

Assumed moisture content of 15%

$$k_4 = 1$$

- Factor for temperature/humidity effect 2.4.3

Factor k_6 , <AS1720.1.2010, CL 2.4.3>

Assumed no modifications need be made with regards to temperature

$$k_6 = 1$$

- Characteristic Bending f'_b Value for structural design, <AS1720.1.2010, T 7.1>

$$f'_s = 4.2 \times 10^3 \text{ kPa}$$

TABLE 7.1
CHARACTERISTIC VALUES FOR STRUCTURAL DESIGN—GL-GRADES

Stress grade	Characteristic values, MPa					
	Bending (%)	Tension parallel to grain (f'_t)	Shear in beam (f'_v)	Compression parallel to grain (f'_c)	Short duration average modulus of elasticity parallel to the grain (E)	Short duration average modulus of rigidity for beams (G)
GL18	45	25	5.0	45	18500	1230
GL17	40	20	4.2	33	16700	1110
GL13	33	16	4.2	26	13300	900
GL12	25	11	4.2	22	11500	770
GL10	22	8	3.7	18	10000	670
GL8	19	6	3.7	14	8000	530

NOTE: The characteristic values for tension for GL grades apply for tension members with the larger cross-sectional dimension not greater than 150 mm. For tension members with a cross-sectional dimension greater than 150 mm, the characteristic values are determined by multiplying the value in the table by $(150/d)^{0.167}$, where d is the larger cross-sectional dimension of the section.

- Shear plane area $A = (2/3) \cdot (bd)$, <AS1720.1.2010, CL 3.2.1.1>

$$A = \frac{2 \times 0.249 \times 0.395}{3} = 0.06557 \text{ m}^2$$

Clause AS1720.1.2010, E3.2(2)

$$V_d = \phi k_1 k_4 k_6 f'_s A_s$$

$$V = 0.85 * 0.57 * 1 * 1 * 4.2 \times 10^3 * 0.06557$$

$$V_d = 133.4 \text{ kN}$$

$$V_d = 133.4 \text{ kN} \geq V^* = 63 \text{ kN}$$

Shear strength demand = 63 kN, less than the allowable limit which is 133.4 kN.

1.2.3 Serviceability Limit Check

Beam deflection check as per AS1170.0.2002, TC1,

$$\text{Max allowable deflection} = \frac{\text{Span}}{300} = \frac{2950}{300} = 9.83 \text{ mm for } 2.9\text{m beams}$$

$$\text{Max allowable deflection} = \frac{\text{Span}}{300} = \frac{4800}{300} = 16 \text{ mm for } 4.8\text{m beams}$$

1.2G + W_u + $\psi_c Q$ combination gave maximum deflection of 2.20 mm in the beam using spacegass model.

Maximum design deflection = 2.20 mm, less than max allowable deflections 9.83 mm and 16 mm.

1.3 Column Design Calculation

Column Dimension

Stress Grade = GL 17

B = 249 mm

D = 260 mm

Governing Load Case

1.2G + 1.5Q = 72.68 kN

C* = 221 kN

V* = 63kN

L = 3.49 m

1.3.1 Compressive Strength

Design compressive capacity parallel to grain, <AS1720.1.2010, 3.3.1.1>

$$N_{d,c} \geq N_c^*$$

Clause AS1720.1.2010, E3.3(2)

$$N_{d,c} = \phi k_1 k_4 k_6 k_{12} f'_c A_c$$

- Capacity Factor ϕ , <AS1720.1.2010, T 2.1>

Category 2 – Elements in house for which failure would be likely to affect an area greater than 25 m².

$$\phi = 0.85$$

- Modification Factor k_1 , <AS1720.1.2010, T 2.3>

For 50+ years duration of the load factor for strength

$$k_1 = 0.57$$

- Factor for in service absorption or desorption of moisture by timber 2.4.2

Seasoning Factor k_4 , <AS1720.1.2010, CL 2.4.2.3>

Assumed moisture content of 15%

$$k_4 = 1$$

- Factor for temperature/humidity effect 2.4.3

Factor k_6 , <AS1720.1.2010, CL 2.4.3>

Assumed no modifications need be made with regards to temperature

$$k_6 = 1$$

- Factor for stability for glued laminated timber 7.4.4

Ratio temporary design action effect/ total design action effect (r) = 0.0027

Material Constant ρ_c for GL 17, <AS1720.1.2010, T 7.2(A)>

$$\rho_c = 0.99$$

TABLE 7.2(B)
MATERIAL CONSTANT, ρ_c , FOR COLUMNS

Stress grade	Ratio temporary design action effect/total design action effect (ρ)*				
	0	0.25	0.5	0.75	1.0
	Material constant (ρ) for columns†				
GL18	1.08	1.08	1.03	1.00	0.98
GL17	0.99	0.99	0.95	0.92	0.90
GL13	0.99	0.99	0.94	0.91	0.89
GL12	0.98	0.98	0.93	0.91	0.89
GL10	0.96	0.96	0.91	0.88	0.86
GL8	0.95	0.95	0.90	0.87	0.85

* See Paragraph E2, Appendix E.

† These values are derived from Equation E2(3), Appendix E, using values of E and f'_c given in Table 7.1.

- Slenderness coefficient for lateral buckling under compression, <AS1720.1.2010, CL 3.3.2.2>

Column resistant systems that act continuously along one edge only and which restrain movement in the direction of the x-axis, AS1720.1.2010, E 3.3(10):

$$S_4 = \frac{3.5 * d}{b}$$

$$S_4 = \frac{3.5 * 0.260}{0.249} = 3.655$$

- Stability Factor, <AS1720.1.2010, CL 3.2.4>

$$\rho_c S_4 = 3.618 \leq 10$$

$$k_{12} = 1$$

- Characteristic value f'_b for Compression parallel to grain for structural design, <AS1720.1.2010, T 7.1>

$$f'_c = 33 \times 10^3 \text{ kPa}$$

TABLE 7.1
CHARACTERISTIC VALUES FOR STRUCTURAL DESIGN—GL-GRADES

Stress grade	Characteristic values, MPa					
	Bending (σ)	Tension parallel to grain (f'_t)	Shear in beam (f'_v)	Compression parallel to grain (f'_c)	Short duration average modulus of elasticity parallel to the grain (E)	Short duration average modulus of rigidity for beams (G)
GL18	45	25	5.0	45	18500	1230
GL17	40	20	4.2	33	16700	1110
GL13	33	16	4.2	26	13300	900
GL12	25	11	4.2	22	11500	770
GL10	22	8	3.7	18	10000	670
GL8	19	6	3.7	14	8000	530

NOTE: The characteristic values for tension for GL grades apply for tension members with the larger cross-sectional dimension not greater than 150 mm. For tension members with a cross-sectional dimension greater than 150 mm, the characteristic values are determined by multiplying the value in the table by $(150/d)^{0.167}$, where d is the larger cross-sectional dimension of the section.

- Cross sectional area of column $A_c = b*d$, <AS1720.1.2010, CL 3.3.1.1>

$$A_c = 0.249 \times 0.260 = 0.06474 \text{ m}^2$$

Clause AS1720.1.2010, E3.3(2)

$$N_{d,c} = \phi k_1 k_4 k_6 k_{12} f'_c A_c$$

$$N_{d,c} = 0.85 * 0.57 * 1 * 1 * 1 * 33 \times 10^3 * 0.06474$$

$$N_{d,c} = 1035.1 \text{ kN}$$

$$N_{d,c} = \mathbf{1035.1 \text{ kN}} \geq N^* = \mathbf{221 \text{ kN}}$$

Compressive strength parallel to grain = 221 kN, less than the allowable limit which is 1035.1 kN.

1.3.2 Bearing Capacity

Design bearing capacity parallel to grain, <AS1720.1.2010, 3.2.6.2>

$$N_{d,l} \geq N_l^*$$

Clause AS1720.1.2010, E3.3(2)

$$N_{d,l} = \phi k_1 k_4 k_6 f'_l A_l$$

- Capacity Factor ϕ , <AS1720.1.2010, T 2.1>

Category 2 – Elements in house for which failure would be likely to affect an area greater than 25 m².

$$\phi = 0.85$$

- Modification Factor k_1 , <AS1720.1.2010, T 2.3>

For 50+ years duration of the load factor for strength

$$k_1 = 0.57$$

- Factor for in service absorption or desorption of moisture by timber 2.4.2

Seasoning Factor k_4 , <AS1720.1.2010, CL 2.4.2.3>

Assumed moisture content of 15%

$$k_4 = 1$$

- Factor for temperature/humidity effect 2.4.3

Factor k_6 , <AS1720.1.2010, CL 2.4.3>

Assumed no modifications need be made with regards to temperature

$$k_6 = 1$$

- Characteristic value f'_l for Compression parallel to grain for structural design, <AS1720.1.2010, T 7.1>

$$f'_l = f'_c = 33 \times 10^3 \text{ kPa}$$

TABLE 7.1
CHARACTERISTIC VALUES FOR STRUCTURAL DESIGN—GL-GRADES

Stress grade	Characteristic values, MPa					
	Bending (f_b)	Tension parallel to grain (f_t)	Shear in beam (f_v)	Compression parallel to grain (f_c)	Short duration average modulus of elasticity parallel to the grain (E)	Short duration average modulus of rigidity for beams (G)
GL18	45	25	5.0	45	18500	1230
GL17	40	20	4.2	33	16700	1110
GL13	33	16	4.2	26	13300	900
GL12	25	11	4.2	22	11500	770
GL10	22	8	3.7	18	10000	670
GL8	19	6	3.7	14	8000	530

NOTE: The characteristic values for tension for GL grades apply for tension members with the larger cross-sectional dimension not greater than 150 mm. For tension members with a cross-sectional dimension greater than 150 mm, the characteristic values are determined by multiplying the value in the table by $(150/d)^{0.167}$, where d is the larger cross-sectional dimension of the section.

- Bearing area for loading parallel to grain $A_l = b \cdot d$, <AS1720.1.2010, CL 3.2.6.2>

$$A_l = 0.249 \times 0.260 = 0.06474 \text{ m}^2$$

Clause AS1720.1.2010, E3.2(17)

$$N_{d,l} = \phi k_1 k_4 k_6 f'_l A_l$$

$$N_{d,l} = 0.85 * 0.57 * 1 * 1 * 40 \times 10^3 * 0.06474$$

$$N_{d,l} = 1254.7 \text{ kN}$$

$$N_{d,l} = 1254.7 \text{ kN} \geq N^* = 221 \text{ kN}$$

Bearing capacity of column parallel to grain = 221 kN, less than the allowable limit which is 1254.7 kN.

1.3.3 Tensile Capacity

Design tensile capacity parallel to grain, <AS1720.1.2010, 3.4.1>

$$N_{d,t} \geq N_t^*$$

Clause AS1720.1.2010, E3.3(2)

$$N_{d,t} = \phi k_1 k_4 k_6 f'_t A_t$$

- Capacity Factor ϕ , <AS1720.1.2010, T 2.1>

Category 2 – Elements in house for which failure would be likely to affect an area greater than 25 m².

$$\phi = 0.85$$

- Modification Factor k_1 , <AS1720.1.2010, T 2.3>

For 50+ years duration of the load factor for strength

$$k_1 = 0.57$$

- Factor for in service absorption or desorption of moisture by timber 2.4.2

Seasoning Factor k_4 , <AS1720.1.2010, CL 2.4.2.3>

Assumed moisture content of 15%

$$k_4 = 1$$

- Factor for temperature/humidity effect 2.4.3

Factor k_6 , <AS1720.1.2010, CL 2.4.3>

Assumed no modifications need be made with regards to temperature

$$k_6 = 1$$

- Characteristic value f'_t for tension parallel to grain for structural design, <AS1720.1.2010, T 7.1>

$$f'_t = 20 \times 10^3 \text{ kPa}$$

TABLE 7.1
CHARACTERISTIC VALUES FOR STRUCTURAL DESIGN—GL-GRADES

Stress grade	Characteristic values, MPa					
	Bending (f'_b)	Tension parallel to grain (f'_t)	Shear in beam (f'_v)	Compression parallel to grain (f'_c)	Short duration average modulus of elasticity parallel to the grain (E)	Short duration average modulus of rigidity for beams (G)
GL18	45	25	5.0	45	18500	1230
GL17	40	20	4.2	33	16700	1110
GL13	33	16	4.2	26	13300	900
GL12	25	11	4.2	22	11500	770
GL10	22	8	3.7	18	10000	670
GL8	19	6	3.7	14	8000	530

NOTE: The characteristic values for tension for GL grades apply for tension members with the larger cross-sectional dimension not greater than 150 mm. For tension members with a cross-sectional dimension greater than 150 mm, the characteristic values are determined by multiplying the value in the table by $(150/d)^{0.167}$, where d is the larger cross-sectional dimension of the section.

- Net cross - section area for loading parallel to grain $A_t = b \cdot d$, <AS1720.1.2010, CL 3.2.6.2>

$$A_t = 0.249 \times 0.260 = 0.06474 \text{ m}^2$$

Clause AS1720.1.2010, E3.2(17)

$$N_{d,t} = \phi k_1 k_4 k_6 f'_t A_t$$

$$N_{d,t} = 0.85 * 0.57 * 1 * 1 * 20 \times 10^3 * 0.06474$$

$$N_{d,t} = 627.33 \text{ kN}$$

$$N_{d,t} = 627.33 \text{ kN} \geq N^* = 0 \text{ kN}$$

Tensile capacity of column parallel to grain is almost nil, which is below the allowable limit of 627.33 kN.

Summary of Costings

The preliminary costing established indicates that the base line of expected values for the modular design and construction will be placed approximately between \$124,000 and \$287,500 and is expected to take approximately 14 weeks from beginning of procurement to final handover. The design detailed in assignment one will take 25 weeks to complete all 16 prefabricated modules and is expected to cost \$237,992.52. This places the design in a competitive position.

Some key findings from assessments made in this document indicate that the combination of CLT and the Glulam columns that we opted for in this design may not have been the optimal choice from a purely structural perspective, though was made in conjunction with the lead architect as to achieve the envisioned design. Ultimately an affordable and sustainable design was achieved that has satisfied the primary constraints.

The report indicates that opting for sustainable and lightweight materials yields both acceptable if not competitive costs and can satisfy the structural design aspects that are necessary for a high confidence and a long-lasting building.

For this project the final costs include GST, overhead and profit allowances which have been established below for individual modules as:

COST SUMMARY	VALUE (%)	VALUE (\$)
DETAILED ASSESSMENT	-	\$189,145.65
PERFORMANCE BONDS AND INSURANCE	-	\$4,728.64
OVERHEAD	+5% base	\$9,693.71
PROFIT	+8% base	\$15,509.94
GST	+10%base	\$18,914.57
FINAL COST	-	\$237,992.52
FINAL COST + LAND ESTIMATE	-	\$409,867.52

Furthermore, the corresponding key schedule dates and times can be noted below:

SCHEDULE SUMMARY	DAYS
TOTAL SCHEDULE TIME	43 weeks
PREFABRICATION TIME	25 weeks
INDIVIDUAL MODULE ASSEMBLY TIME	11 days

ID	Task Mode	Task Name	Duration	Free Slack	Total Slack	Start	Finish	Qtr 1, 2020			Qtr 2, 2020			Qtr 3, 2020			Qtr 4, 2020			Qtr 1, 2021
								Jan	Feb	Mar	Apr	May	Jun	Jul	Aug	Sep	Oct	Nov	Dec	Jan
1		1 Project Commencement	213 days	0 days	0 days	Mon 24/02/20	Wed 16/12/20													
2		1.1 Project Planning	60 days	0 days	0 days	Mon 24/02/20	Fri 15/05/20													
3		1.1.1 Project Proposal	5 days	0 days	0 days	Mon 24/02/20	Fri 28/02/20													
4		1.2 Design Phase	117 days	0 days	0 days	Mon 2/03/20	Tue 11/08/20													
5		1.2.1 Project Brief	1 day	0 days	0 days	Mon 2/03/20	Mon 2/03/20													
6		1.2.2 Conceptual Design	9 days	0 days	0 days	Tue 3/03/20	Fri 13/03/20													
7		1.2.3 Architectural Design	20 days	10 days	10 days	Mon 16/03/20	Fri 10/04/20													
8		1.2.4 Engineering Design	30 days	0 days	0 days	Mon 16/03/20	Fri 24/04/20													
9		1.2.5 Design Alternations	5 days	0 days	0 days	Mon 27/04/20	Fri 1/05/20													
10		1.2.6 Final Design Review	2 days	0 days	0 days	Mon 4/05/20	Tue 5/05/20													
11		1.2.7 Bill of Quantity	5 days	0 days	0 days	Wed 6/05/20	Tue 12/05/20													
12		1.2.8 Approximate Estimation	5 days	0 days	0 days	Wed 6/05/20	Tue 12/05/20													
13		1.2.9 Detail Estimations	5 days	0 days	0 days	Wed 6/05/20	Tue 12/05/20													
14		1.2.10 Client Approval	10 days	0 days	0 days	Wed 13/05/20	Tue 26/05/20													
15		1.2.11 Council Approvals	55 days	0 days	0 days	Wed 27/05/20	Tue 11/08/20													
16		1.3 Procurement	25 days	0 days	0 days	Wed 12/08/20	Tue 15/09/20													
17		1.3.1 Procure Material	25 days	0 days	0 days	Wed 12/08/20	Tue 15/09/20													
18		1.3.1.1 Provide Member Drawings and Obtain Quotation	5 days	0 days	0 days	Wed 12/08/20	Tue 18/08/20													
19		1.3.1.2 Timber Beams and Columns - special order	20 days	0 days	0 days	Wed 19/08/20	Tue 15/09/20													
20		1.3.1.3 CLT panels - special order	20 days	0 days	0 days	Wed 19/08/20	Tue 15/09/20													
21		1.3.1.4 E-joists ana E-beams - special order	20 days	0 days	0 days	Wed 19/08/20	Tue 15/09/20													
22		1.3.1.5 Windows and Doors	20 days	0 days	0 days	Wed 19/08/20	Tue 15/09/20													
23		1.3.1.6 Other panel items - insulation,battens, internal finishes etc	20 days	0 days	0 days	Wed 19/08/20	Tue 15/09/20													
24		1.3.1.7 Order Utility items - electrical, plumbing etc	20 days	0 days	0 days	Wed 19/08/20	Tue 15/09/20													
25		1.3.2 Procure Steel Connections	25 days	0 days	0 days	Wed 12/08/20	Tue 15/09/20													
26		1.3.2.1 Provide Connection Design Drawings and Obtain Quotation	5 days	0 days	0 days	Wed 12/08/20	Tue 18/08/20													
27		1.3.2.2 Prefabricate Steel Connection	20 days	0 days	0 days	Wed 19/08/20	Tue 15/09/20													
28		1.3.3 Procure Prefabricated Staircase	25 days	12 days	12 days	Wed 12/08/20	Tue 15/09/20													
29		1.3.3.1 Provide Drawings and Obtain Quotation	5 days	0 days	12 days	Wed 12/08/20	Tue 18/08/20													
30		1.3.3.2 Prefabricated Stairs	20 days	10 days	12 days	Wed 19/08/20	Tue 15/09/20													
31		1.4 Preconstructed foundation	3 days	0 days	0 days	Wed 12/08/20	Fri 14/08/20													
32		1.4.1 Site Clearance Confirmed	1 day	0 days	0 days	Wed 12/08/20	Wed 12/08/20													

Project: Multi-storey Modular Construction
Date: Wed 13/05/20

Task		Manual Task		Deadline		Critical Split	
Split		Duration-only		Path Predecessor Milestone Task		Baseline	
Milestone		Manual Summary Rollup		Path Predecessor Summary Task		Baseline Milestone	
Summary		Manual Summary		Path Predecessor Normal Task		Baseline Summary	
Project Summary		Start-only		Path Driving Predecessor Milestone Task		Progress	
Inactive Task		Finish-only		Path Driving Predecessor Summary Task		Manual Progress	
Inactive Milestone		External Tasks		Path Driving Predecessor Normal Task		Slack	
Inactive Summary		External Milestone		Critical			

ID	Task Mode	Task Name	Duration	Free Slack	Total Slack	Start	Finish	Qtr 1, 2020			Qtr 2, 2020			Qtr 3, 2020			Qtr 4, 2020			Qtr 1, 2021
								Jan	Feb	Mar	Apr	May	Jun	Jul	Aug	Sep	Oct	Nov	Dec	Jan
33		1.4.2 Underground Services Check	3 days	0 days	0 days	Wed 12/08/20	Fri 14/08/20													
34		1.4.3 Check Concrete Slab Grading	2 days	0 days	0 days	Wed 12/08/20	Thu 13/08/20													
35		1.4.4 Prepare Crane Lift Locations - On site	1 day	0 days	0 days	Fri 14/08/20	Fri 14/08/20													
36		1.5 Prepare Warehouse	5 days	20 days	20 days	Wed 12/08/20	Tue 18/08/20													
37		1.5.1 Confirm transport route accessibility	1 day	34 days	36 days	Wed 12/08/20	Wed 12/08/20													
38		1.5.2 Set up Warehouse	5 days	20 days	20 days	Wed 12/08/20	Tue 18/08/20													
39		1.6 Delivery	1 day	2 days	2 days	Wed 30/09/20	Wed 30/09/20													
40		1.6.1 Prefabricated Stairs/ Shaft Delivery	1 day	0 days	2 days	Wed 30/09/20	Wed 30/09/20													
41		1.7 Modules Assembly & Transport	56 days	0 days	0 days	Wed 16/09/20	Wed 2/12/20													
42		1.7.1 Erect Module 1	9 days	0 days	0 days	Wed 16/09/20	Mon 28/09/20													
43		1.7.1.1 Assemble Frame	1 day	0 days	0 days	Wed 16/09/20	Wed 16/09/20													
44		1.7.1.2 Floor Panel including floor service	2 days	0 days	0 days	Thu 17/09/20	Fri 18/09/20													
45		1.7.1.3 Wall Panel including electrical Services	2 days	0 days	0 days	Mon 21/09/20	Tue 22/09/20													
46		1.7.1.4 Roof Panel	2 days	0 days	0 days	Wed 23/09/20	Thu 24/09/20													
47		1.7.1.5 Window and door Assembly	1 day	6 days	6 days	Fri 25/09/20	Fri 25/09/20													
48		1.7.1.6 Kitchen and Bathroom fitouts	1 day	0 days	0 days	Fri 25/09/20	Fri 25/09/20													
49		1.7.1.7 Internal and External Finishes	1 day	0 days	0 days	Mon 28/09/20	Mon 28/09/20													
50		1.7.1.8 Assemble Detachable Balconies	1 day	5 days	5 days	Mon 28/09/20	Mon 28/09/20													
51		1.7.2 Warehouse Testing	1 day	0 days	0 days	Tue 29/09/20	Tue 29/09/20													
52		1.7.2.1 Trial Lift and Quality Check	1 day	0 days	0 days	Tue 29/09/20	Tue 29/09/20													
53		1.7.3 Transport Module 1	1 day	0 days	0 days	Fri 2/10/20	Fri 2/10/20													
54		1.7.3.1 Pilot Vehicle for Transport	1 day	0 days	0 days	Fri 2/10/20	Fri 2/10/20													
55		1.7.3.2 Truck	1 day	0 days	0 days	Fri 2/10/20	Fri 2/10/20													
56		1.7.4 Erect Module 2	11 days	0 days	0 days	Mon 21/09/20	Mon 5/10/20													
57		1.7.4.1 Assemble South Side - Storey 2	11 days	0 days	0 days	Mon 21/09/20	Mon 5/10/20													
58		1.7.5 Transport Module 2	1 day	0 days	0 days	Mon 5/10/20	Mon 5/10/20													
59		1.7.5.1 Transportation	1 day	0 days	0 days	Mon 5/10/20	Mon 5/10/20													
60		1.7.6 Erect Module 3	11 days	1 day	1 day	Thu 24/09/20	Thu 8/10/20													
61		1.7.6.1 Assemble South Side - Storey 3	11 days	1 day	1 day	Thu 24/09/20	Thu 8/10/20													
62		1.7.7 Transport Module 3	1 day	0 days	0 days	Fri 9/10/20	Fri 9/10/20													
63		1.7.7.1 Transportation	1 day	0 days	0 days	Fri 9/10/20	Fri 9/10/20													
64		1.7.8 Erect Module 4	11 days	0 days	0 days	Tue 29/09/20	Tue 13/10/20													
65		1.7.8.1 Assemble South Side - Storey 4	11 days	0 days	0 days	Tue 29/09/20	Tue 13/10/20													
66		1.7.9 Transport Module 4	1 day	0 days	0 days	Tue 13/10/20	Tue 13/10/20													
67		1.7.9.1 Transportation	1 day	0 days	0 days	Tue 13/10/20	Tue 13/10/20													
68		1.7.10 Erect Module 5	11 days	1 day	1 day	Fri 2/10/20	Fri 16/10/20													

Project: Multi-storey Modular Construction
Date: Wed 13/05/20

Task		Manual Task		Deadline		Critical Split	
Split		Duration-only		Path Predecessor Milestone Task		Baseline	
Milestone		Manual Summary Rollup		Path Predecessor Summary Task		Baseline Milestone	
Summary		Manual Summary		Path Predecessor Normal Task		Baseline Summary	
Project Summary		Start-only		Path Driving Predecessor Milestone Task		Progress	
Inactive Task		Finish-only		Path Driving Predecessor Summary Task		Manual Progress	
Inactive Milestone		External Tasks		Path Driving Predecessor Normal Task		Slack	
Inactive Summary		External Milestone		Critical			

ID	Task Mode	Task Name	Duration	Free Slack	Total Slack	Start	Finish	Qtr 1, 2020			Qtr 2, 2020			Qtr 3, 2020			Qtr 4, 2020			Qtr 1, 2021
								Jan	Feb	Mar	Apr	May	Jun	Jul	Aug	Sep	Oct	Nov	Dec	Jan
69		1.7.10.1 Assemble East Side - Storey 1	11 days	1 day	1 day	Fri 2/10/20	Fri 16/10/20													
70		1.7.11 Transport Module 5	1 day	0 days	0 days	Mon 19/10/20	Mon 19/10/20													
71		1.7.11.1 Transportation	1 day	0 days	0 days	Mon 19/10/20	Mon 19/10/20													
72		1.7.12 Erect Module 6	11 days	2 days	2 days	Wed 7/10/20	Wed 21/10/20													
73		1.7.12.1 Assemble East Side - Storey 2	11 days	2 days	2 days	Wed 7/10/20	Wed 21/10/20													
74		1.7.13 Transport Module 6	1 day	0 days	0 days	Fri 23/10/20	Fri 23/10/20													
75		1.7.13.1 Transportation	1 day	0 days	0 days	Fri 23/10/20	Fri 23/10/20													
76		1.7.14 Erect Module 7	11 days	3 days	3 days	Mon 12/10/20	Mon 26/10/20													
77		1.7.14.1 Assemble East Side - Storey 3	11 days	3 days	3 days	Mon 12/10/20	Mon 26/10/20													
78		1.7.15 Transport Module 7	1 day	0 days	0 days	Thu 29/10/20	Thu 29/10/20													
79		1.7.15.1 Transportation	1 day	0 days	0 days	Thu 29/10/20	Thu 29/10/20													
80		1.7.16 Erect Module 8	11 days	3 days	3 days	Thu 15/10/20	Thu 29/10/20													
81		1.7.16.1 Assemble East Side - Storey 4	11 days	3 days	3 days	Thu 15/10/20	Thu 29/10/20													
82		1.7.17 Transport Module 8	1 day	0 days	0 days	Tue 3/11/20	Tue 3/11/20													
83		1.7.17.1 Transportation	1 day	0 days	0 days	Tue 3/11/20	Tue 3/11/20													
84		1.7.18 Erect Module 9	11 days	3 days	3 days	Tue 20/10/20	Tue 3/11/20													
85		1.7.18.1 Assemble North Side - Storey 1	11 days	3 days	3 days	Tue 20/10/20	Tue 3/11/20													
86		1.7.19 Transport Module 9	1 day	0 days	0 days	Fri 6/11/20	Fri 6/11/20													
87		1.7.19.1 Transportation	1 day	0 days	0 days	Fri 6/11/20	Fri 6/11/20													
88		1.7.20 Erect Module 10	11 days	2 days	2 days	Fri 23/10/20	Fri 6/11/20													
89		1.7.20.1 Assemble North Side - Storey 2	11 days	2 days	2 days	Fri 23/10/20	Fri 6/11/20													
90		1.7.21 Transport Module 10	1 day	0 days	0 days	Tue 10/11/20	Tue 10/11/20													
91		1.7.21.1 Transportation	1 day	0 days	0 days	Tue 10/11/20	Tue 10/11/20													
92		1.7.22 Erect Module 11	11 days	3 days	3 days	Wed 28/10/20	Wed 11/11/20													
93		1.7.22.1 Assemble North Side - Storey 3	11 days	3 days	3 days	Wed 28/10/20	Wed 11/11/20													
94		1.7.23 Transport Module 11	1 day	0 days	0 days	Mon 16/11/20	Mon 16/11/20													
95		1.7.23.1 Transportation	1 day	0 days	0 days	Mon 16/11/20	Mon 16/11/20													
96		1.7.24 Erect Module 12	11 days	3 days	3 days	Mon 2/11/20	Mon 16/11/20													
97		1.7.24.1 Assemble North Side - Storey 4	11 days	3 days	3 days	Mon 2/11/20	Mon 16/11/20													
98		1.7.25 Transport Module 12	1 day	0 days	0 days	Thu 19/11/20	Thu 19/11/20													
99		1.7.25.1 Transportation	1 day	0 days	0 days	Thu 19/11/20	Thu 19/11/20													
100		1.7.26 Erect Module 13	11 days	3 days	3 days	Thu 5/11/20	Thu 19/11/20													
101		1.7.26.1 Assemble West Side - Storey 1	11 days	3 days	3 days	Thu 5/11/20	Thu 19/11/20													
102		1.7.27 Transport Module 13	1 day	0 days	0 days	Tue 24/11/20	Tue 24/11/20													
103		1.7.27.1 Transportation	1 day	0 days	0 days	Tue 24/11/20	Tue 24/11/20													
104		1.7.28 Erect Module 14	11 days	2 days	2 days	Tue 10/11/20	Tue 24/11/20													
105		1.7.28.1 Assemble West Side - Storey 2	11 days	2 days	2 days	Tue 10/11/20	Tue 24/11/20													

Project: Multi-storey Modular Construction
Date: Wed 13/05/20

Task		Manual Task		Deadline		Critical Split	
Split		Duration-only		Path Predecessor Milestone Task		Baseline	
Milestone		Manual Summary Rollup		Path Predecessor Summary Task		Baseline Milestone	
Summary		Manual Summary		Path Predecessor Normal Task		Baseline Summary	
Project Summary		Start-only		Path Driving Predecessor Milestone Task		Progress	
Inactive Task		Finish-only		Path Driving Predecessor Summary Task		Manual Progress	
Inactive Milestone		External Tasks		Path Driving Predecessor Normal Task		Slack	
Inactive Summary		External Milestone		Critical			

ID	Task Mode	Task Name	Duration	Free Slack	Total Slack	Start	Finish	Qtr 1, 2020			Qtr 2, 2020			Qtr 3, 2020			Qtr 4, 2020			Qtr 1, 2021
								Jan	Feb	Mar	Apr	May	Jun	Jul	Aug	Sep	Oct	Nov	Dec	Jan
106		1.7.29 Transport Module 14	1 day	0 days	0 days	Thu 26/11/20	Thu 26/11/20													
107		1.7.29.1 Transportation	1 day	0 days	0 days	Thu 26/11/20	Thu 26/11/20													
108		1.7.30 Erect Module 15	11 days	1 day	1 day	Fri 13/11/20	Fri 27/11/20													
109		1.7.30.1 Assemble West Side - Storey 3	11 days	1 day	1 day	Fri 13/11/20	Fri 27/11/20													
110		1.7.31 Transport Module 15	1 day	0 days	0 days	Mon 30/11/20	Mon 30/11/20													
111		1.7.31.1 Transportation	1 day	0 days	0 days	Mon 30/11/20	Mon 30/11/20													
112		1.7.32 Erect Module 16	11 days	0 days	0 days	Wed 18/11/20	Wed 2/12/20													
113		1.7.32.1 Assemble West Side - Storey 4	11 days	0 days	0 days	Wed 18/11/20	Wed 2/12/20													
114		1.7.33 Transport Module 16	1 day	0 days	0 days	Wed 2/12/20	Wed 2/12/20													
116		1.8 Plant and Operator Hire	49 days	0 days	0 days	Tue 29/09/20	Fri 4/12/20													
117		1.8.1 Crane	48 days	0 days	0 days	Tue 29/09/20	Thu 3/12/20													
118		1.8.2 Boom Lift	48 days	0 days	0 days	Wed 30/09/20	Fri 4/12/20													
119		1.9 Onsite Assembly	52 days	0 days	0 days	Thu 1/10/20	Fri 11/12/20													
120		1.9.1 Position Stairs/Shaft	1 day	0 days	2 days	Thu 1/10/20	Thu 1/10/20													
121		1.9.2 South Side Lifts	10 days	1 day	2 days	Fri 2/10/20	Thu 15/10/20													
122		1.9.3 East Side Lifts	13 days	1 day	1 day	Mon 19/10/20	Wed 4/11/20													
123		1.9.4 North Side Lifts	12 days	0 days	0 days	Fri 6/11/20	Mon 23/11/20													
124		1.9.5 West Side Lifts	10 days	0 days	0 days	Tue 24/11/20	Mon 7/12/20													
125		1.9.6 External building attachments	2 days	2 days	2 days	Tue 8/12/20	Wed 9/12/20													
126		1.9.7 Essential Services Connection	4 days	0 days	0 days	Tue 8/12/20	Fri 11/12/20													
127		1.10 Building Commissioning	3 days	0 days	0 days	Mon 14/12/20	Wed 16/12/20													
128		1.10.1 Onsite Testing	1 day	0 days	0 days	Mon 14/12/20	Mon 14/12/20													
129		1.10.2 Handover Documents	2 days	0 days	0 days	Tue 15/12/20	Wed 16/12/20													

Project: Multi-storey Modular Construction Date: Wed 13/05/20	Task		Manual Task		Deadline		Critical Split	
	Split		Duration-only		Path Predecessor Milestone Task		Baseline	
	Milestone		Manual Summary Rollup		Path Predecessor Summary Task		Baseline Milestone	
	Summary		Manual Summary		Path Predecessor Normal Task		Baseline Summary	
	Project Summary		Start-only		Path Driving Predecessor Milestone Task		Progress	
	Inactive Task		Finish-only		Path Driving Predecessor Summary Task		Manual Progress	
	Inactive Milestone		External Tasks		Path Driving Predecessor Normal Task		Slack	
Inactive Summary		External Milestone		Critical				

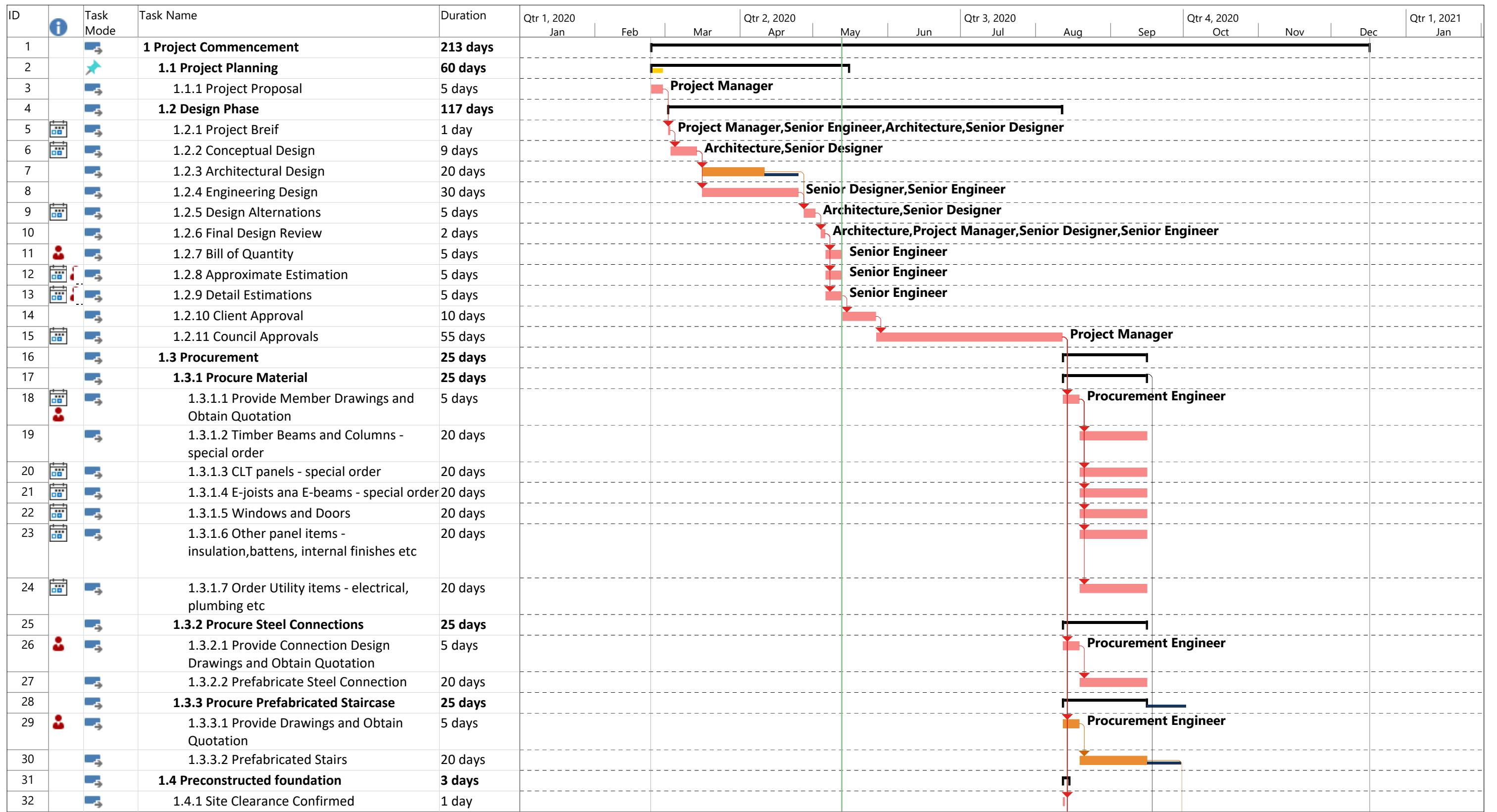

Project: Multi-storey Modular Construction Date: Wed 13/05/20	Task		Manual Task		Deadline		Critical Split	
	Split		Duration-only		Path Predecessor Milestone Task		Baseline	
	Milestone		Manual Summary Rollup		Path Predecessor Summary Task		Baseline Milestone	
	Summary		Manual Summary		Path Predecessor Normal Task		Baseline Summary	
	Project Summary		Start-only		Path Driving Predecessor Milestone Task		Progress	
	Inactive Task		Finish-only		Path Driving Predecessor Summary Task		Manual Progress	
	Inactive Milestone		External Tasks		Path Driving Predecessor Normal Task		Slack	
	Inactive Summary		External Milestone		Critical			

ID	Task Mode	Task Name	Duration	Qtr 1, 2020			Qtr 2, 2020			Qtr 3, 2020			Qtr 4, 2020			Qtr 1, 2021
				Jan	Feb	Mar	Apr	May	Jun	Jul	Aug	Sep	Oct	Nov	Dec	Jan
33		1.4.2 Underground Services Check	3 days													
34		1.4.3 Check Concrete Slab Grading	2 days													
35		1.4.4 Prepare Crane Lift Locations - On site	1 day													
36		1.5 Prepare Warehouse	5 days													
37		1.5.1 Confirm transport route accessibility	1 day													
38		1.5.2 Set up Warehouse	5 days													
39		1.6 Delivery	1 day													
40		1.6.1 Prefabricated Stairs/ Shaft Delivery	1 day													
41		1.7 Modules Assembly & Transport	56 days													
42		1.7.1 Erect Module 1	9 days													
43		1.7.1.1 Assemble Frame	1 day													
44		1.7.1.2 Floor Panel including floor service	2 days													
45		1.7.1.3 Wall Panel including electrical Services	2 days													
46		1.7.1.4 Roof Panel	2 days													
47		1.7.1.5 Window and door Assembly	1 day													
48		1.7.1.6 Kitchen and Bathroom fitouts	1 day													
49		1.7.1.7 Internal and External Finishes	1 day													
50		1.7.1.8 Assemble Detachable Balconies	1 day													
51		1.7.2 Warehouse Testing	1 day													
52		1.7.2.1 Trial Lift and Quality Check	1 day													
53		1.7.3 Transport Module 1	1 day													
54		1.7.3.1 Pilot Vehicle for Transport	1 day													
55		1.7.3.2 Truck	1 day													
56		1.7.4 Erect Module 2	11 days													
57		1.7.4.1 Assemble South Side - Storey 2	11 days													
58		1.7.5 Transport Module 2	1 day													
59		1.7.5.1 Transportation	1 day													
60		1.7.6 Erect Module 3	11 days													
61		1.7.6.1 Assemble South Side - Storey 3	11 days													
62		1.7.7 Transport Module 3	1 day													
63		1.7.7.1 Transportation	1 day													
64		1.7.8 Erect Module 4	11 days													
65		1.7.8.1 Assemble South Side - Storey 4	11 days													
66		1.7.9 Transport Module 4	1 day													
67		1.7.9.1 Transportation	1 day													
68		1.7.10 Erect Module 5	11 days													

Project: Multi-storey Modular Construction
Date: Wed 13/05/20

Task		Manual Task		Deadline		Critical Split	
Split		Duration-only		Path Predecessor Milestone Task		Baseline	
Milestone		Manual Summary Rollup		Path Predecessor Summary Task		Baseline Milestone	
Summary		Manual Summary		Path Predecessor Normal Task		Baseline Summary	
Project Summary		Start-only		Path Driving Predecessor Milestone Task		Progress	
Inactive Task		Finish-only		Path Driving Predecessor Summary Task		Manual Progress	
Inactive Milestone		External Tasks		Path Driving Predecessor Normal Task		Slack	
Inactive Summary		External Milestone		Critical			

ID	Task Mode	Task Name	Duration	Qtr 1, 2020			Qtr 2, 2020			Qtr 3, 2020			Qtr 4, 2020			Qtr 1, 2021
				Jan	Feb	Mar	Apr	May	Jun	Jul	Aug	Sep	Oct	Nov	Dec	Jan
69		1.7.10.1 Assemble East Side - Storey 1	11 days													
70		1.7.11 Transport Module 5	1 day													
71		1.7.11.1 Transportation	1 day													
72		1.7.12 Erect Module 6	11 days													
73		1.7.12.1 Assemble East Side - Storey 2	11 days													
74		1.7.13 Transport Module 6	1 day													
75		1.7.13.1 Transportation	1 day													
76		1.7.14 Erect Module 7	11 days													
77		1.7.14.1 Assemble East Side - Storey 3	11 days													
78		1.7.15 Transport Module 7	1 day													
79		1.7.15.1 Transportation	1 day													
80		1.7.16 Erect Module 8	11 days													
81		1.7.16.1 Assemble East Side - Storey 4	11 days													
82		1.7.17 Transport Module 8	1 day													
83		1.7.17.1 Transportation	1 day													
84		1.7.18 Erect Module 9	11 days													
85		1.7.18.1 Assemble North Side - Storey 1	11 days													
86		1.7.19 Transport Module 9	1 day													
87		1.7.19.1 Transportation	1 day													
88		1.7.20 Erect Module 10	11 days													
89		1.7.20.1 Assemble North Side - Storey 2	11 days													
90		1.7.21 Transport Module 10	1 day													
91		1.7.21.1 Transportation	1 day													
92		1.7.22 Erect Module 11	11 days													
93		1.7.22.1 Assemble North Side - Storey 3	11 days													
94		1.7.23 Transport Module 11	1 day													
95		1.7.23.1 Transportation	1 day													
96		1.7.24 Erect Module 12	11 days													
97		1.7.24.1 Assemble North Side - Storey 4	11 days													
98		1.7.25 Transport Module 12	1 day													
99		1.7.25.1 Transportation	1 day													
100		1.7.26 Erect Module 13	11 days													
101		1.7.26.1 Assemble West Side - Storey 1	11 days													
102		1.7.27 Transport Module 13	1 day													
103		1.7.27.1 Transportation	1 day													
104		1.7.28 Erect Module 14	11 days													
105		1.7.28.1 Assemble West Side - Storey 2	11 days													

Project: Multi-storey Modular Construction Date: Wed 13/05/20	Task		Manual Task		Deadline		Critical Split	
	Split		Duration-only		Path Predecessor Milestone Task		Baseline	
	Milestone		Manual Summary Rollup		Path Predecessor Summary Task		Baseline Milestone	
	Summary		Manual Summary		Path Predecessor Normal Task		Baseline Summary	
	Project Summary		Start-only		Path Driving Predecessor Milestone Task		Progress	
	Inactive Task		Finish-only		Path Driving Predecessor Summary Task		Manual Progress	
	Inactive Milestone		External Tasks		Path Driving Predecessor Normal Task		Slack	
	Inactive Summary		External Milestone		Critical			

ID	Task Mode	Task Name	Duration	Qtr 1, 2020			Qtr 2, 2020			Qtr 3, 2020			Qtr 4, 2020			Qtr 1, 2021
				Jan	Feb	Mar	Apr	May	Jun	Jul	Aug	Sep	Oct	Nov	Dec	Jan
106		1.7.29 Transport Module 14	1 day													
107		1.7.29.1 Transportation	1 day													
108		1.7.30 Erect Module 15	11 days													
109		1.7.30.1 Assemble West Side - Storey 3	11 days													
110		1.7.31 Transport Module 15	1 day													
111		1.7.31.1 Transportation	1 day													
112		1.7.32 Erect Module 16	11 days													
113		1.7.32.1 Assemble West Side - Storey 4	11 days													
114		1.7.33 Transport Module 16	1 day													
116		1.8 Plant and Operator Hire	49 days													
117		1.8.1 Crane	48 days													
118		1.8.2 Boom Lift	48 days													
119		1.9 Onsite Assembly	52 days													
120		1.9.1 Position Stairs/Shaft	1 day													
121		1.9.2 South Side Lifts	10 days													
122		1.9.3 East Side Lifts	13 days													
123		1.9.4 North Side Lifts	12 days													
124		1.9.5 West Side Lifts	10 days													
125		1.9.6 External building attachments	2 days													
126		1.9.7 Essential Services Connection	4 days													
127		1.10 Building Commissioning	3 days													
128		1.10.1 Onsite Testing	1 day													
129		1.10.2 Handover Documents	2 days													



Project: Multi-storey Modular Construction Date: Wed 13/05/20	Task		Manual Task		Deadline		Critical Split	
	Split		Duration-only		Path Predecessor Milestone Task		Baseline	
	Milestone		Manual Summary Rollup		Path Predecessor Summary Task		Baseline Milestone	
	Summary		Manual Summary		Path Predecessor Normal Task		Baseline Summary	
	Project Summary		Start-only		Path Driving Predecessor Milestone Task		Progress	
	Inactive Task		Finish-only		Path Driving Predecessor Summary Task		Manual Progress	
	Inactive Milestone		External Tasks		Path Driving Predecessor Normal Task		Slack	
	Inactive Summary		External Milestone		Critical			